



# 超高速包缝机 B9500系列

---

SUPER HIGH-SPEED OVERLOCK SEWING MACHINE

使用说明书  
OPERATION MANUAL

零件手册  
PARTS BOOK

浙江中捷缝纫科技有限公司  
ZOJE SEWING MACHINE CO., LTD.



## 为了安全

对于缝纫机本身及各种装置，我们充分考虑到他的安全性。请遵照基本的操作方法，安全的进行工作。

- 拆除为保证安全所设置的装置、零件的情况下使用，是非常危险的，请绝对不要拆除后使用。
- 缝纫机在使用时，请不要在缝纫机台板上放置工具及缝纫时不必要的东西。
- 在对缝纫机进行检修、调节、清扫、穿线、换针等时，为防止发生事故，务必请切断电源。在确定即使踩缝纫机踏板，缝纫机也不动之后，再进行操作。



## CAUTION

Observe the safety precautions though takes the utmost care to produce safe sewing machines and devices,operstors should follow these basic safety rules.

- To prevent accidents,do not remove safety devices or parts while operating the machine.
- Do not leave tools or other unnecessary objects on the machine table while operating the machine.
- Before maintenance,adjusting,clearing, threading or replacing the needle,and to prevent accidents,be sure the power is turned dff.Check that the machine will not operate when the pedal is pressed.

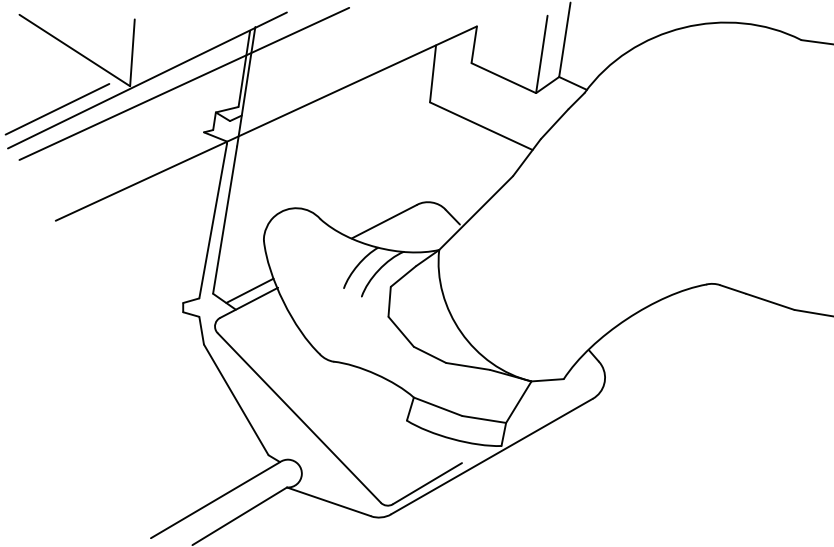

- 在离开缝纫机台时，请务必关掉电源。
- 停电时也请务必关掉电源。
- 为了总是安全地、运转良好的使用缝纫机，经常的检查是不可缺少的。请予以注意。
- Turn the power off before leaving the machine table.
- In the event of a power failure,be sure to turn the machine off.
- Check that the machine is securely grounded

# 台板加工图

## Schematic diagram of the machine table

请参照下图进行台板的加工

Cut the table referring to the diagram

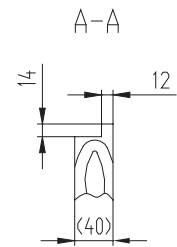
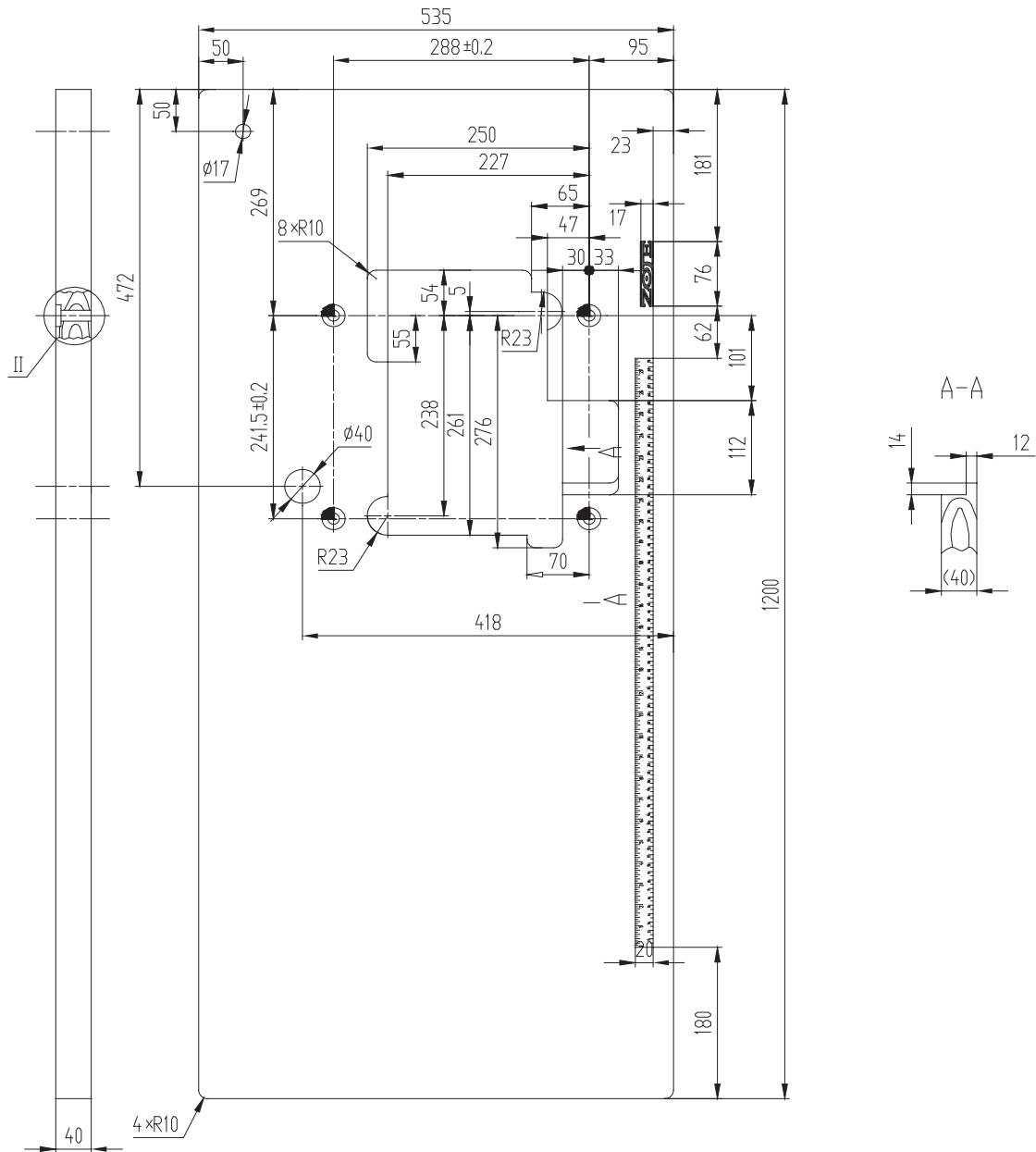

标准尺寸  
Standard dimension

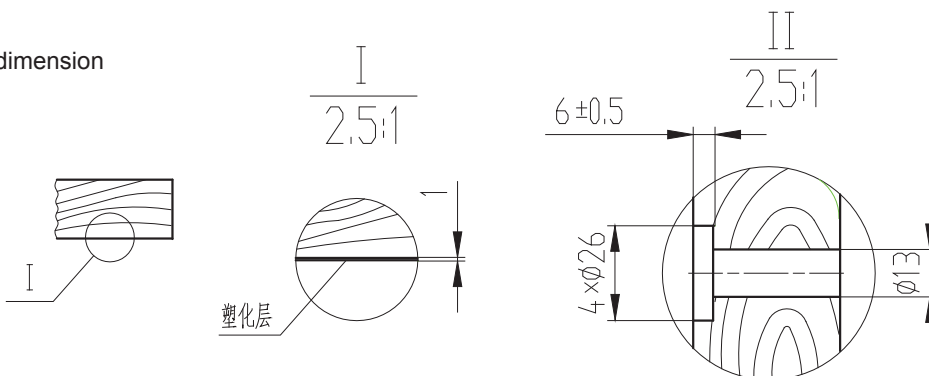

## 加润滑油 Lubrication

加油量是使油面处于H线与L线之间为好。  
当油量低于L线时，就要及时补充机油。

After filling the oil , the top of the indicator  
should lie between (H)and(L) lines.

Add oil,when the oil level indicator reaches or  
goes below(L).

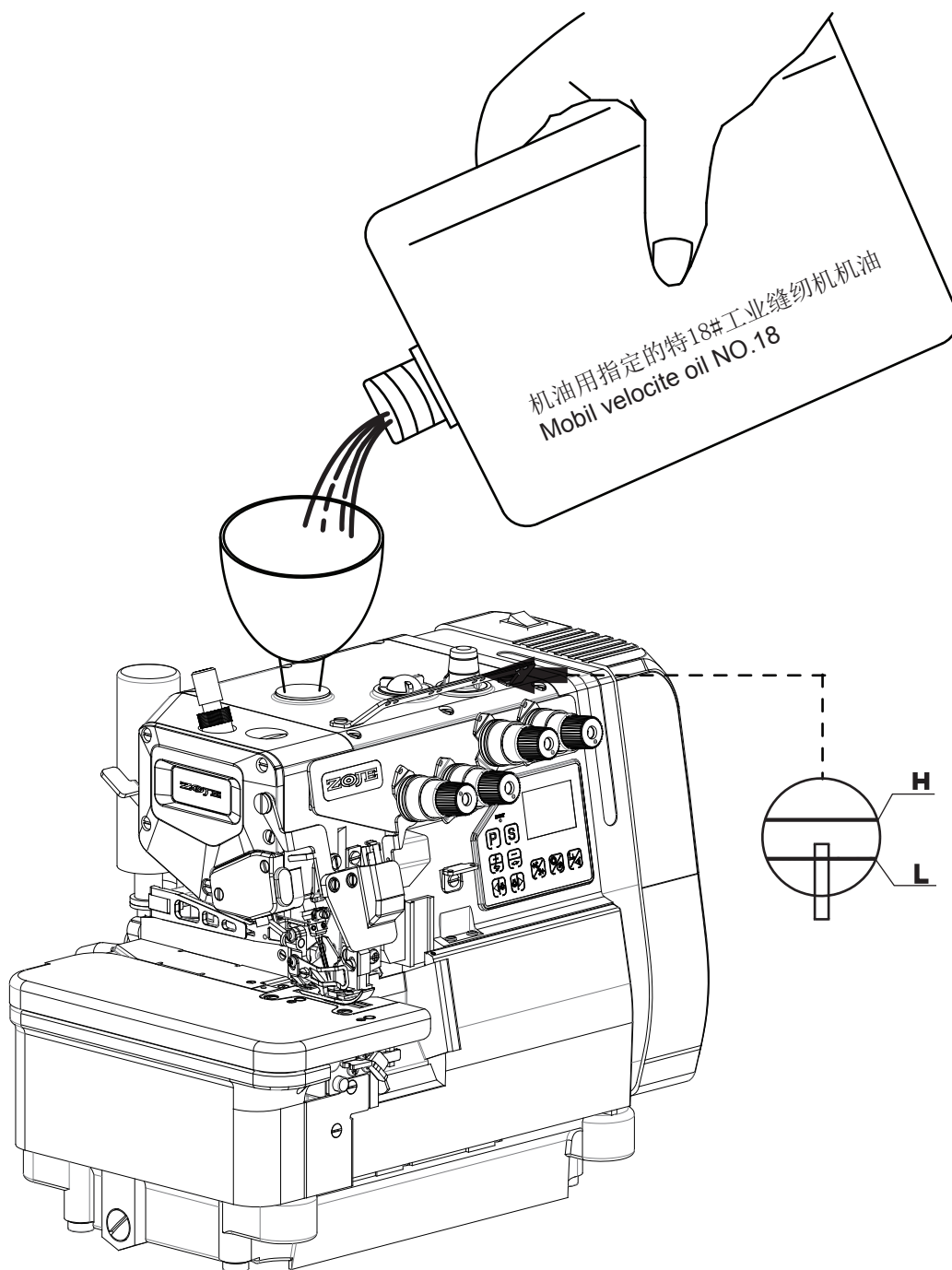

## 手动给油 Manual Lubrication

手动给油是在缝纫机最初开始使用时。  
或相当一段时间没使用了时，请供给  
2-3滴油。

Apply 2 or 3 drops of oil by hand when the  
machine is used for the first time or has  
been left unused for some time.



机油用特18#工业缝纫机油  
Mobil velocite oil NO.18

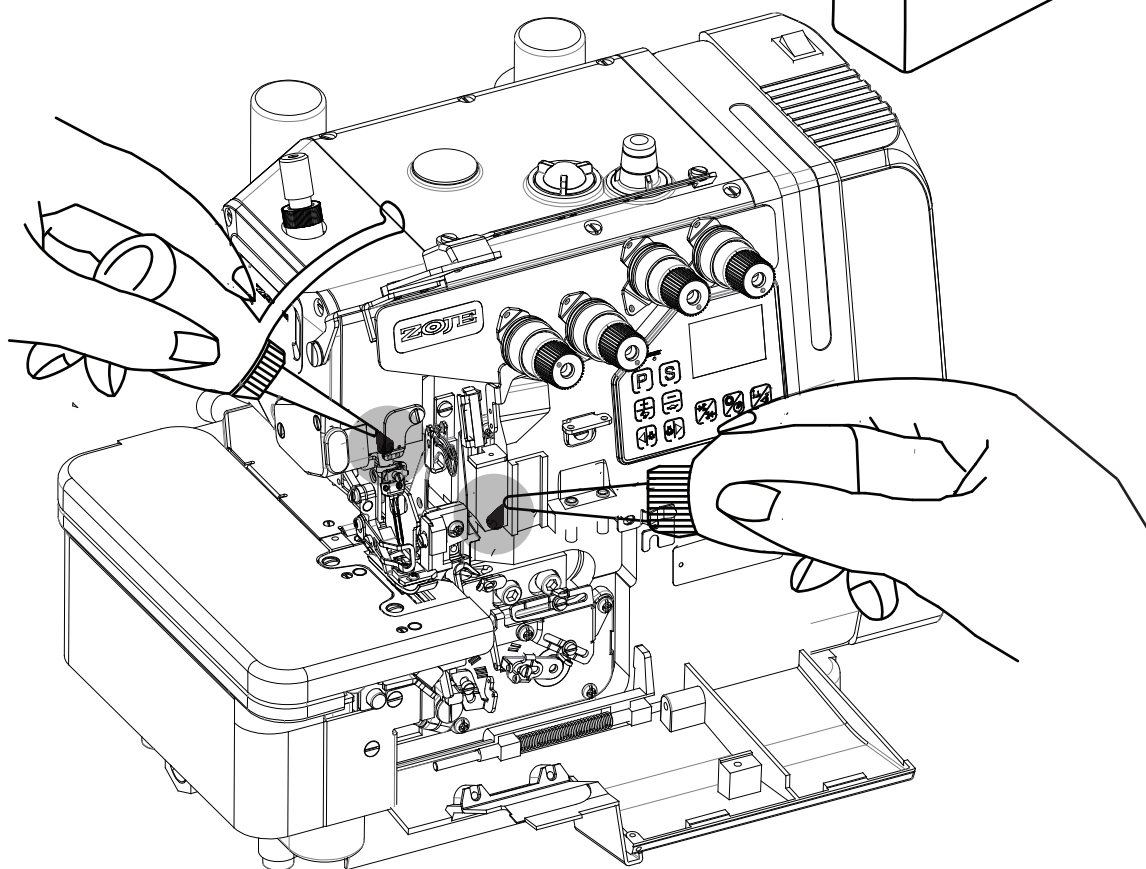

## 给HR装置供油 Filling the HR device with silicon oil

为了防止断线，尽早给HR装置供油。  
注：关于购买硅油，请咨询代理店或公司  
营业部联系。

Fill the HR device oil before it is too low in order  
to prevent needle thread breakage and fabric  
damage.

Note: Use Zoje recommended silicon oil.  
[UNION CARBIDE CORPORATION]  
UCC L-45(10)

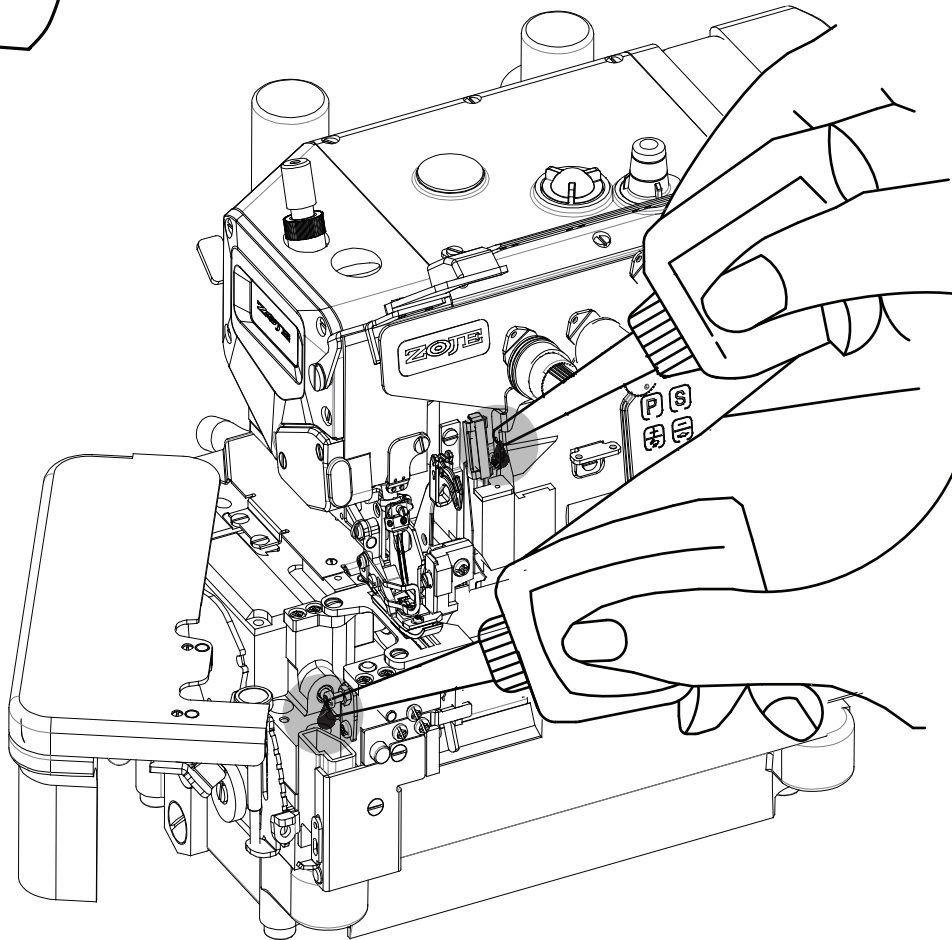

# 穿线的方法 Threading

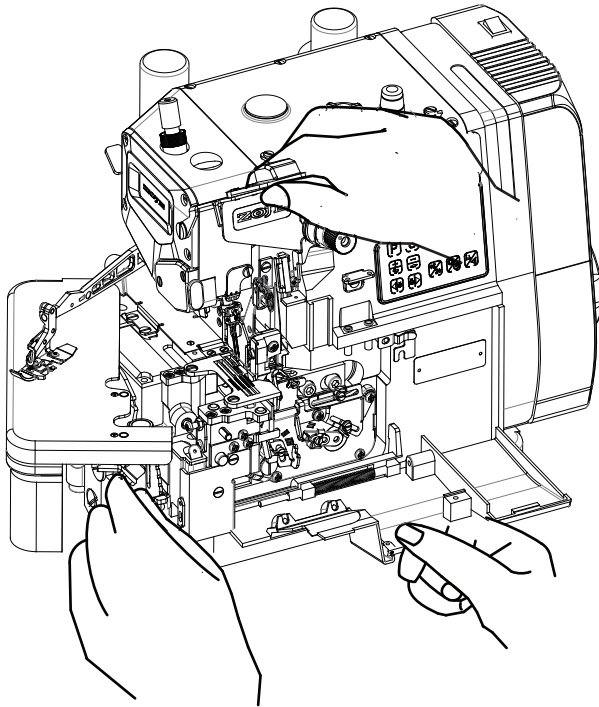

① 打开防护罩、大盖及前盖，再移开压脚  
Open three covers and remove the  
presser foot aside.

把机器上原有的线与缝纫  
用线绑结在一起。  
② Knot the preset thread and the  
thread being used together to  
thread the machine.

针线  
Needle thread

将线拉到针眼前，剪掉  
结头再次穿好针线。  
Trim the knots off neatly  
before passing through  
the eye of the needle to  
rethread

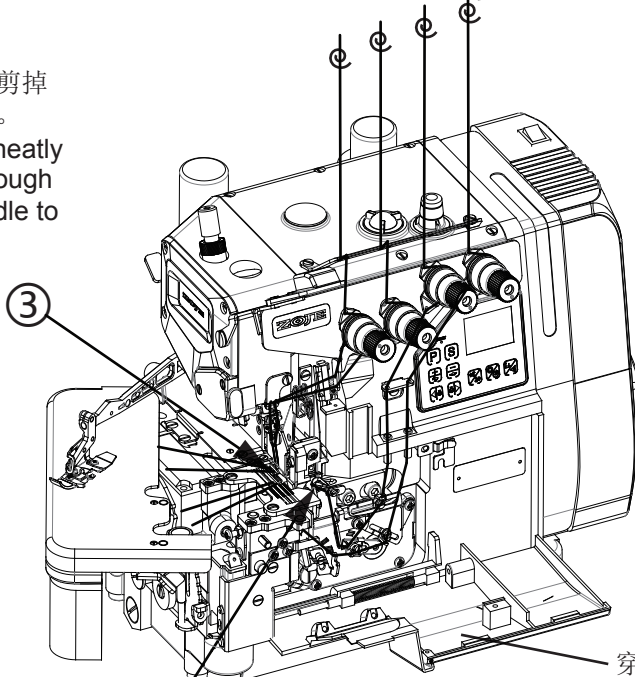

若机上原来没有线，请参照穿线  
图正确进行穿线。

threaded correctly by referring  
to the threading diagram.

穿线图  
Threading diagram

弯针线  
Looper thread

线拉出接头后，用剪刀齐接头。  
Trim the knots off neatly  
after passing through the  
eye of the looper.

④

## 压脚压力的调节 Adjusting the presser foot pressure

压脚压力的调节，松动螺母①，调节螺母②，在送布得到稳定状态下尽可能使用较弱的压力为好。

Loosen adjusting nut ① and turn adjusting nut ② to adjust the presser foot pressure. It should be as light as possible. Yet be sufficient to obtain the proper stitch formation.

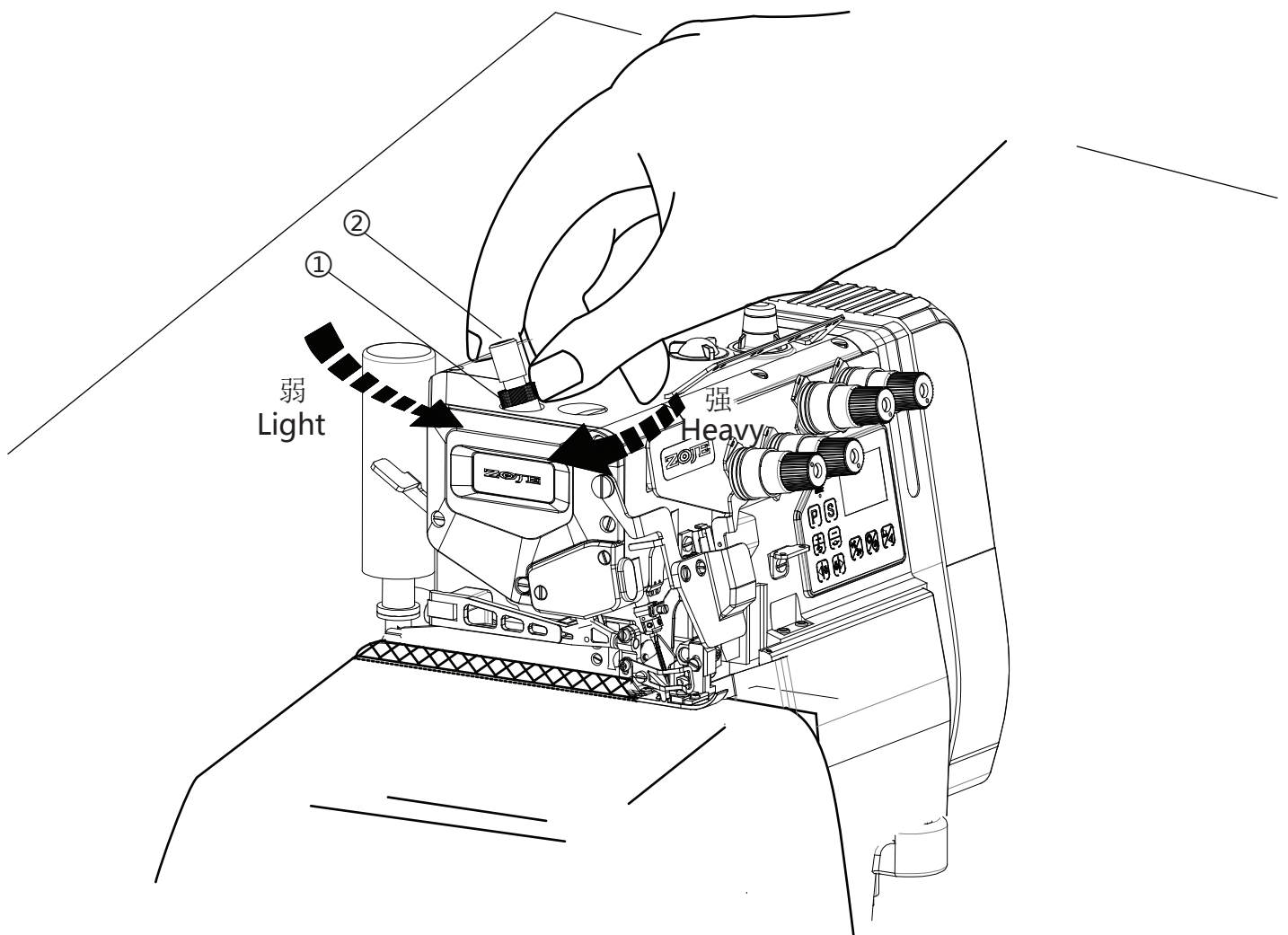



## 差动比的调节 Adjusting the diff. feed ratio

差动比的调节  
松开螺母①，然后调节差动调节杆②。

Loosen the nut ① and turn the adjusting rod ② to adjust the differential feed ratio .

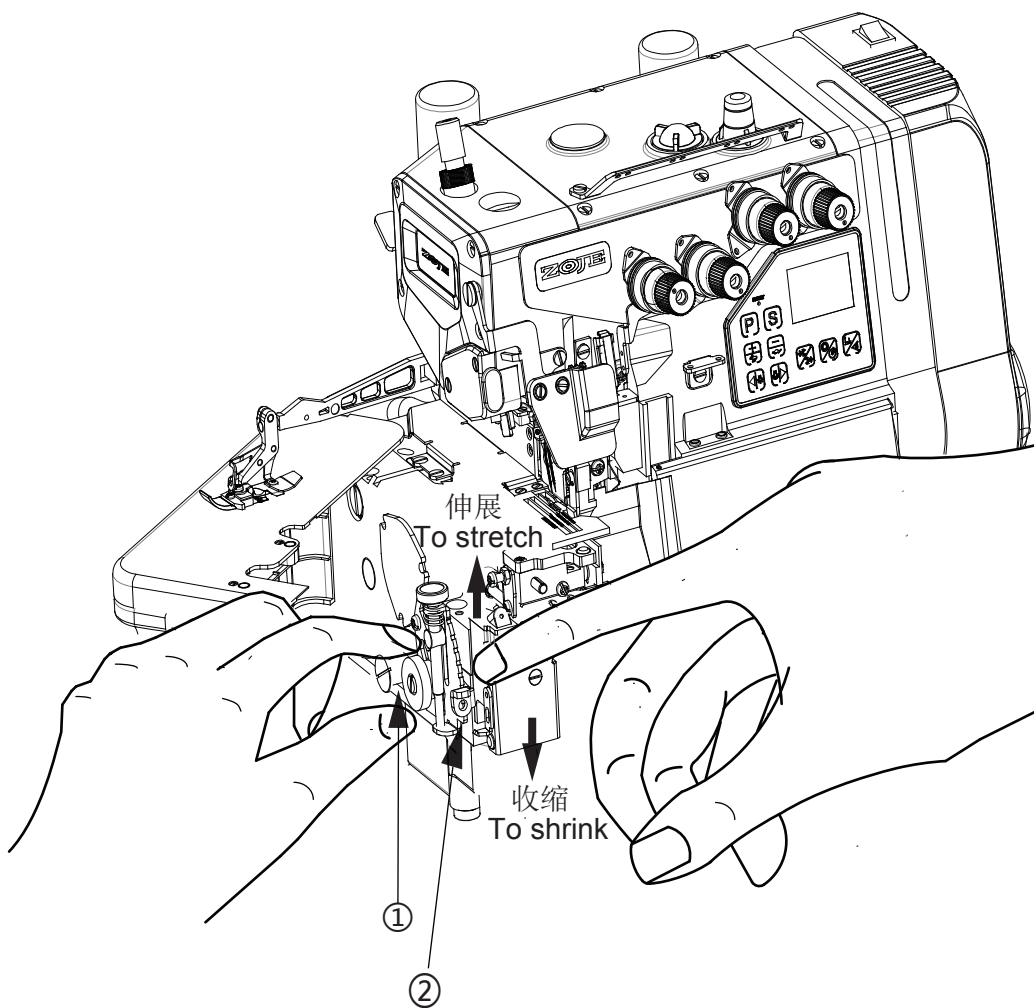

## 针脚长度的调节 Adjusting the stitch length

1. 摁住按钮，旋转手轮，按钮会陷进更深处。 ① While pressing the push button, turn the handwheel to seek the position at which the push button goes further into the depth.
2. 这时边摁住按钮，边转动手轮，使校准标记号对准所希望的数值。 ② Then, keeping the push button pressed, turn the handwheel and set the desired scale to the aligning mark.

注：针脚长度的调节务必请在调节差动比之后进行。

**Note:** Stitch length adjustment must only be made after the differential feed ratio has been changed.

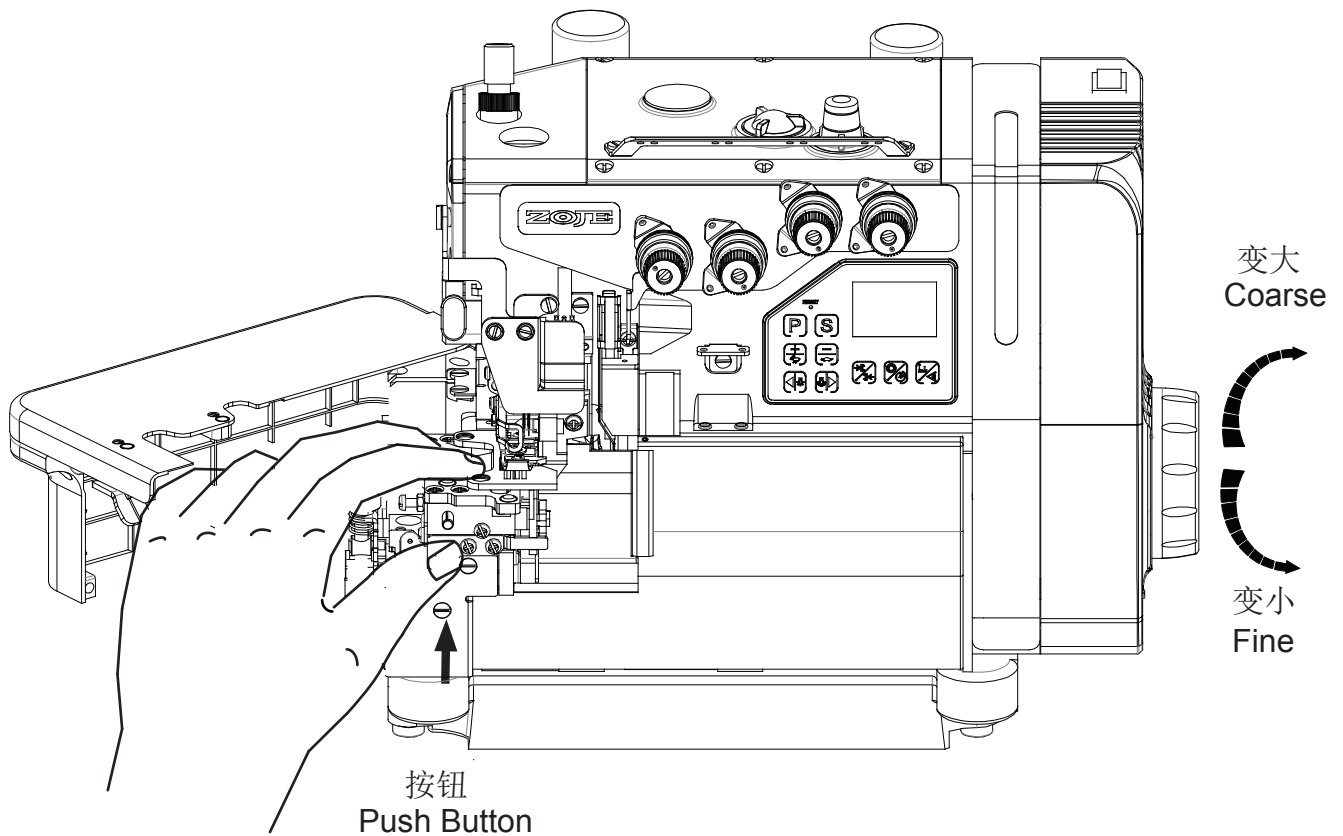

## 线张力的调节 Adujsting the thread tension

线张力状态的调节，请用针线调节螺帽①、上弯针线调节螺帽②、弯针线调节螺帽③来进行调节。

Make tension adjustments with the needle thread knob①、the upper looper knob②、and the lower looper knob③.

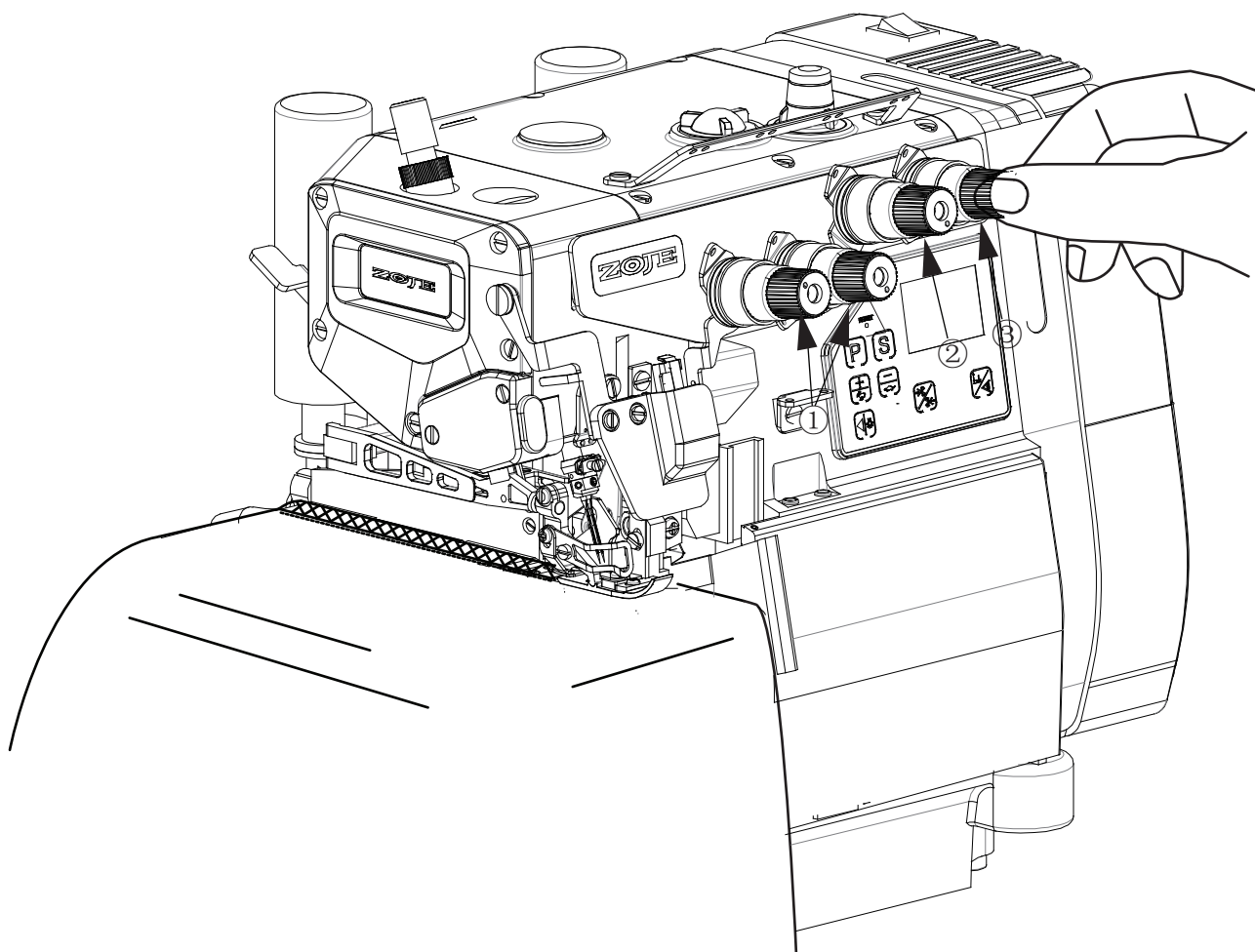
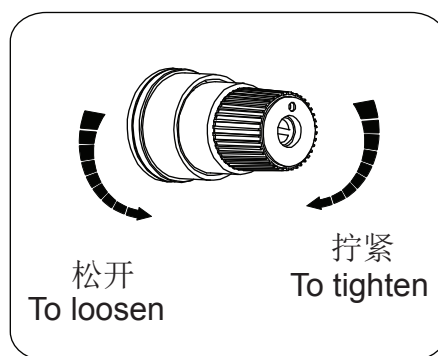

## 清洁缝纫机 Cleaning the machine

缝纫机的清扫，以针板槽及送布牙周围为主。

Mainly the slots of the needle plate and the feed rows should be cleaned

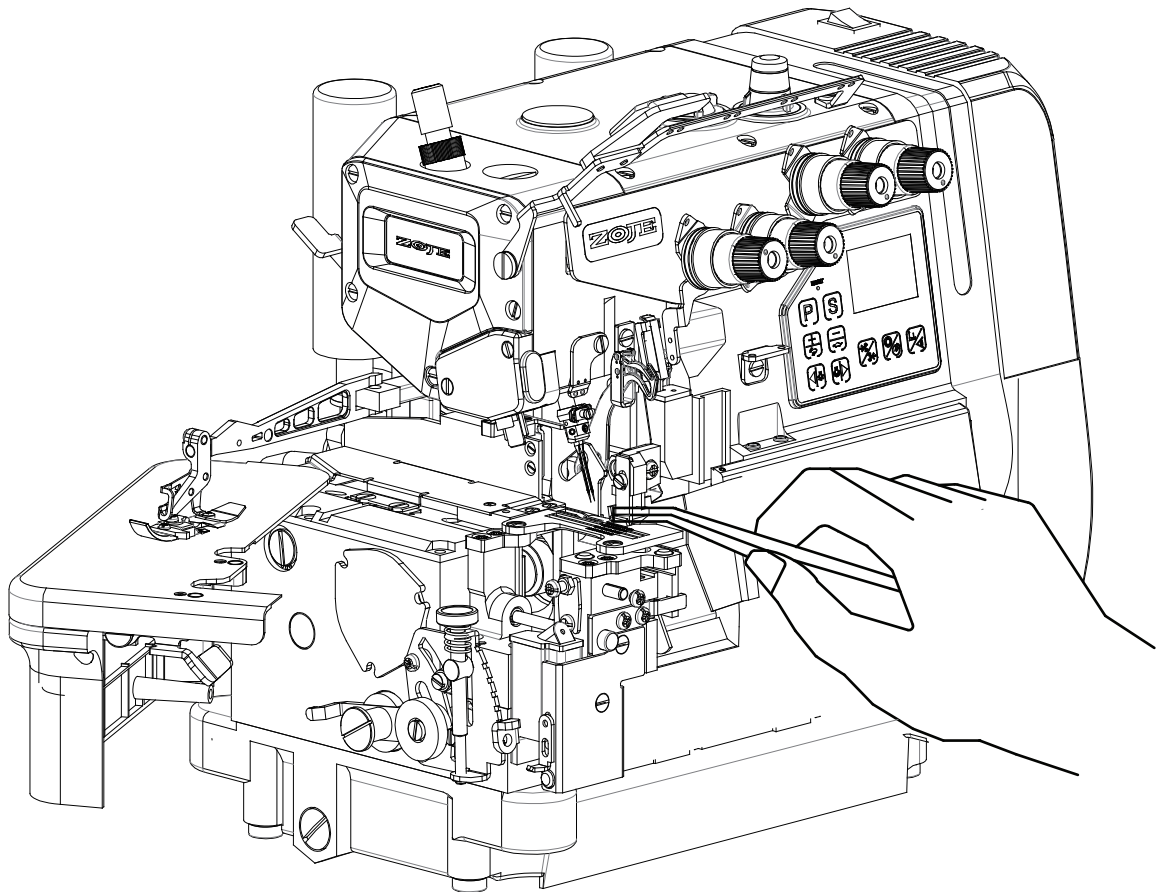

# 换机针

## Replacing the needle

准确辨认针的前后，请将针凹向着后方，  
即背向操作者进行安装。  
针要牢固的插到孔的最深处。

- \* Check the needle carefully to see that the scarf is turded to the rear of the machine.
- \* Insert the needle to the proper depth, and fasten securely.

标准使用针：DC×27  
Standard needle: DC×27

**OK! NO!**

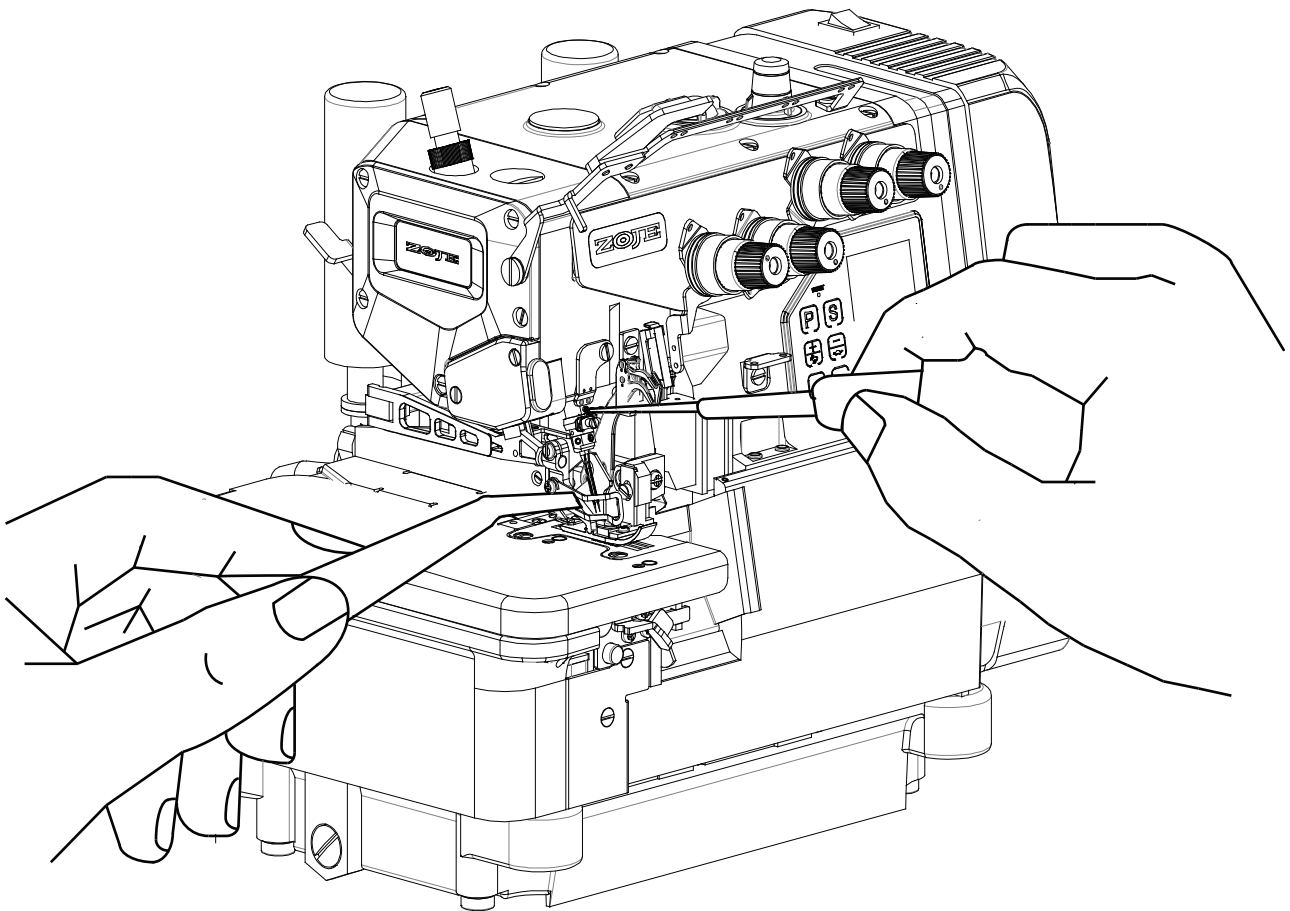
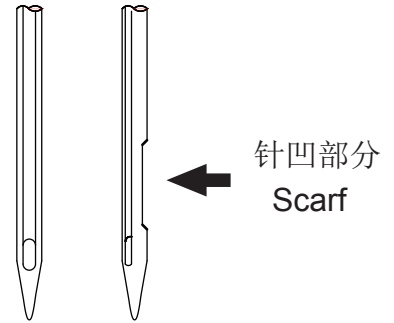

# 检查机油的循环

## Checking the oil circulation

**OK!** 运转中  
(Operating)

↓

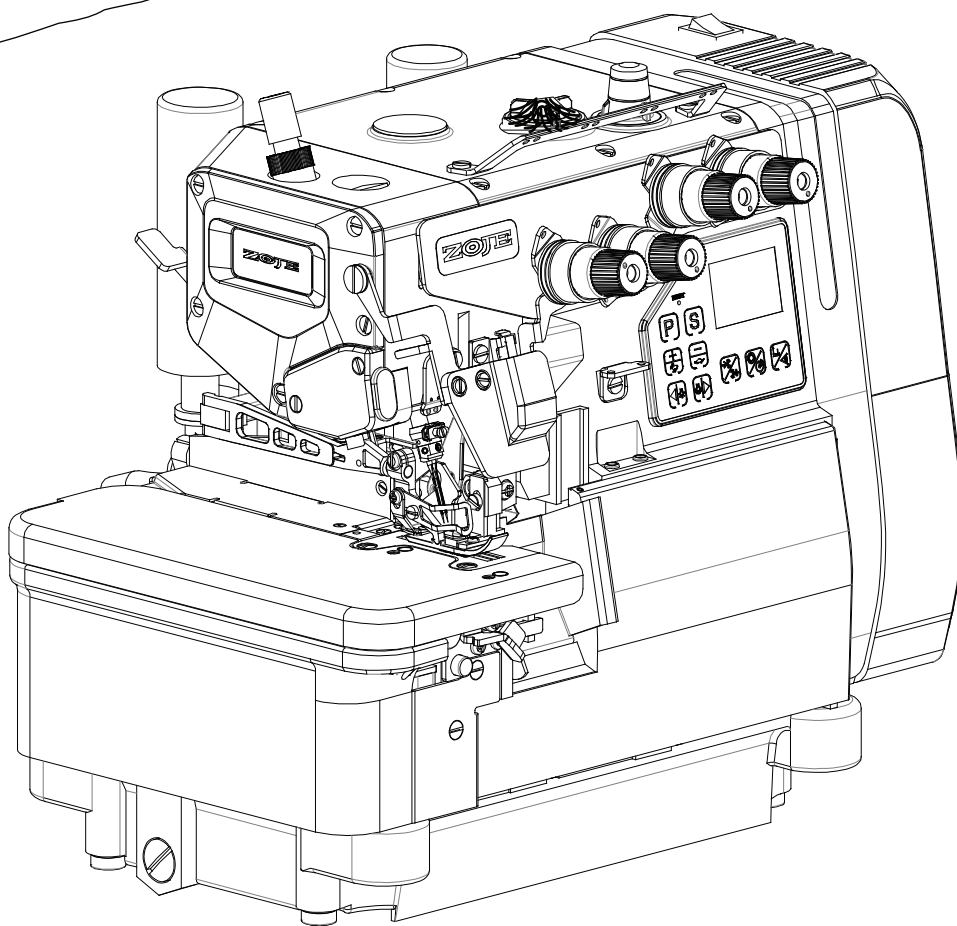

## 检查和更换滤油器 Checking and replacing the oil filter

滤油器每6个月检查并更换。

Check and replace the oil filter every six months.

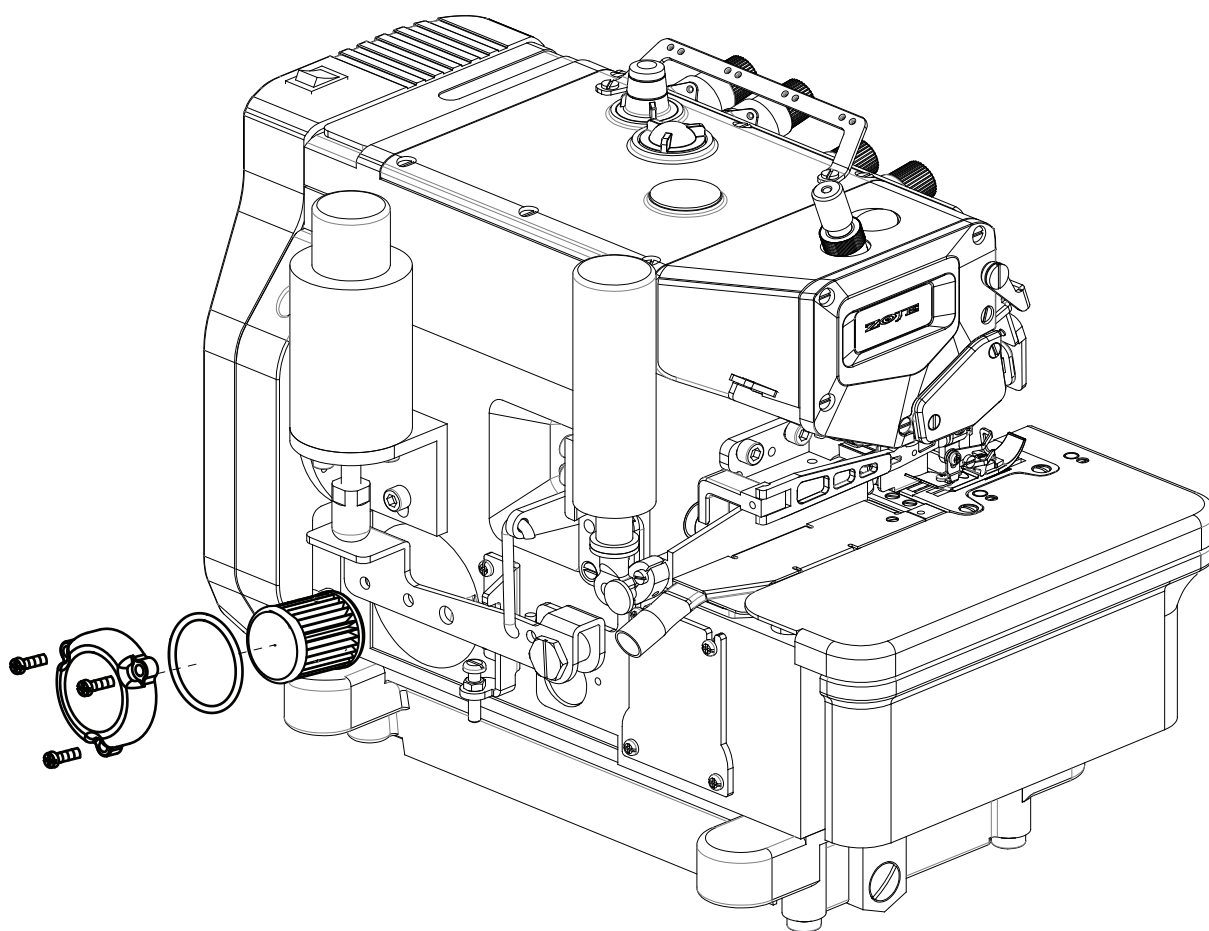

## 换机油 Replacing the oil

机油的更换，请在使用开始1个月后更换一次。然后，每6个月更换一次。

Replacing the oil one month after the first use and every six months thereafter.

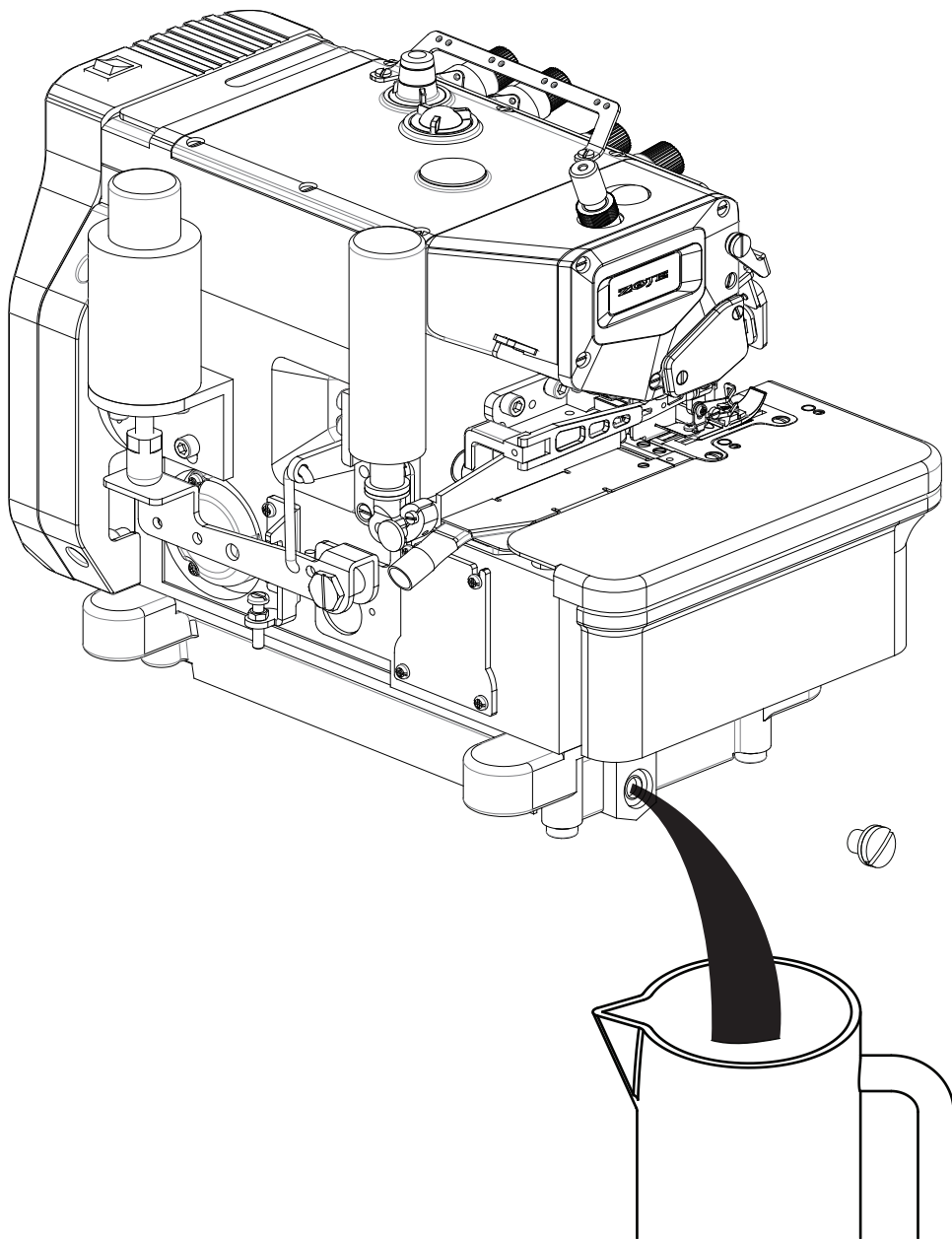



# 下刀片的更换 Replacing the lower knife

## 卸下下刀片

To remove the lower knife

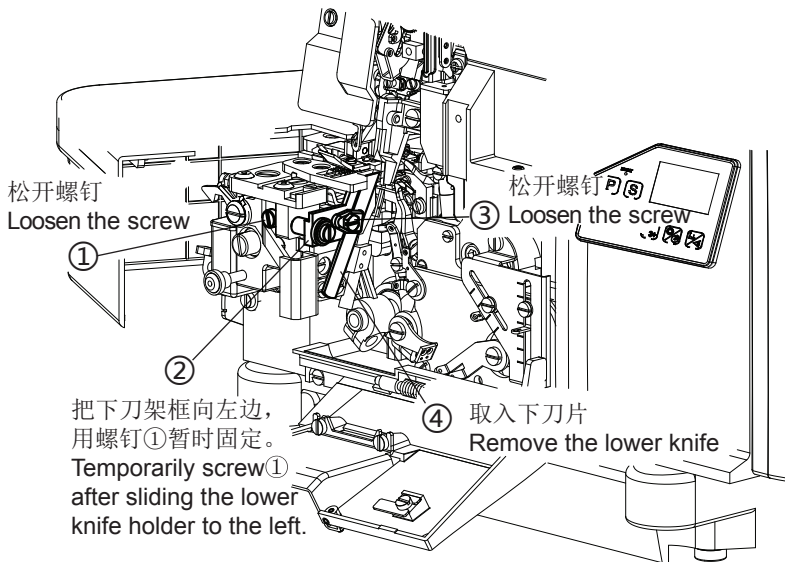

下刀片正确的研磨角度  
Correct angles to resharpen the lower knife

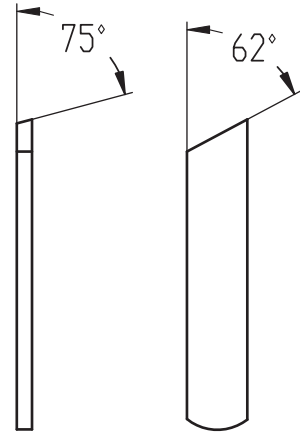

## 安装下刀片

To replace the lower knife

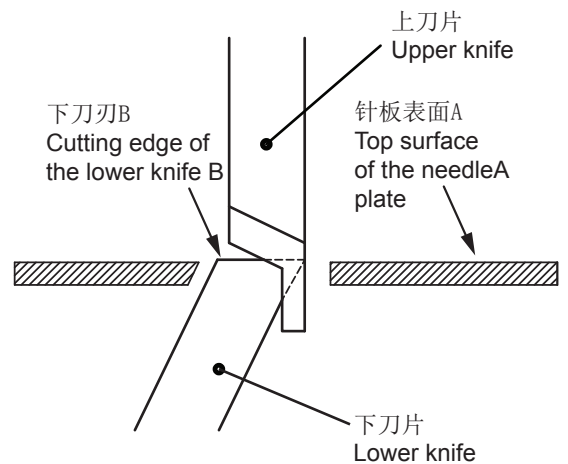
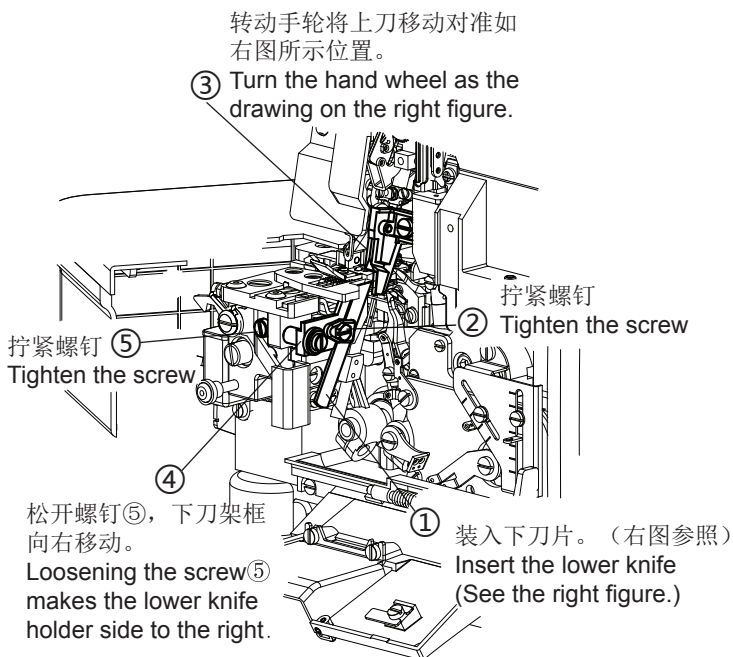

使针板表面A与下刀刃B处于相同水平位置。  
Level of [A]=Level of [B]

装好下刀片后进行剪线，确认剪线状况。  
Check cutting action of knife.

1. 机壳部件/ HOUSING FRAME

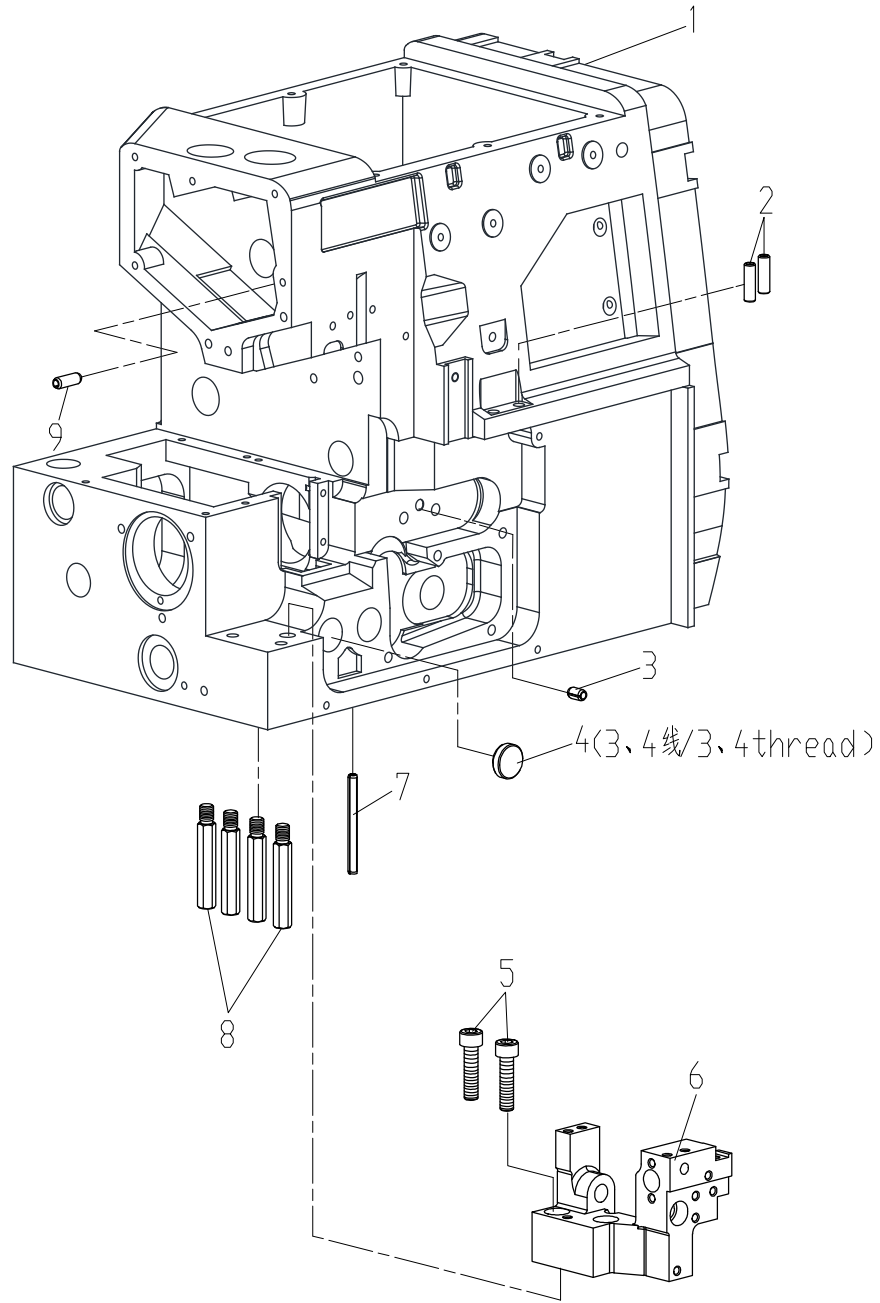

### 1. 机壳部件/HOUSING FRAME

序号 No.	件号 Parts No.	名称	Description	数量 QT.
1	20023847	机壳敲套组件	housing	1
2	10054228	上、下弯针穿线管	threading pipe for upper and lower loopers	2
3	10002836	销	pin	1
4	10008961	橡胶塞	rubber plug	1
5	10009171	螺钉	screw	2
6	10009050	下刀座	lower knife bed	1
7	10002830	销	pin	1
8	10011847	机壳支柱	support for housing	4
9	10002833	销	pin	1

2. 外罩部件 (1) / OUT COVER FRAME (1)

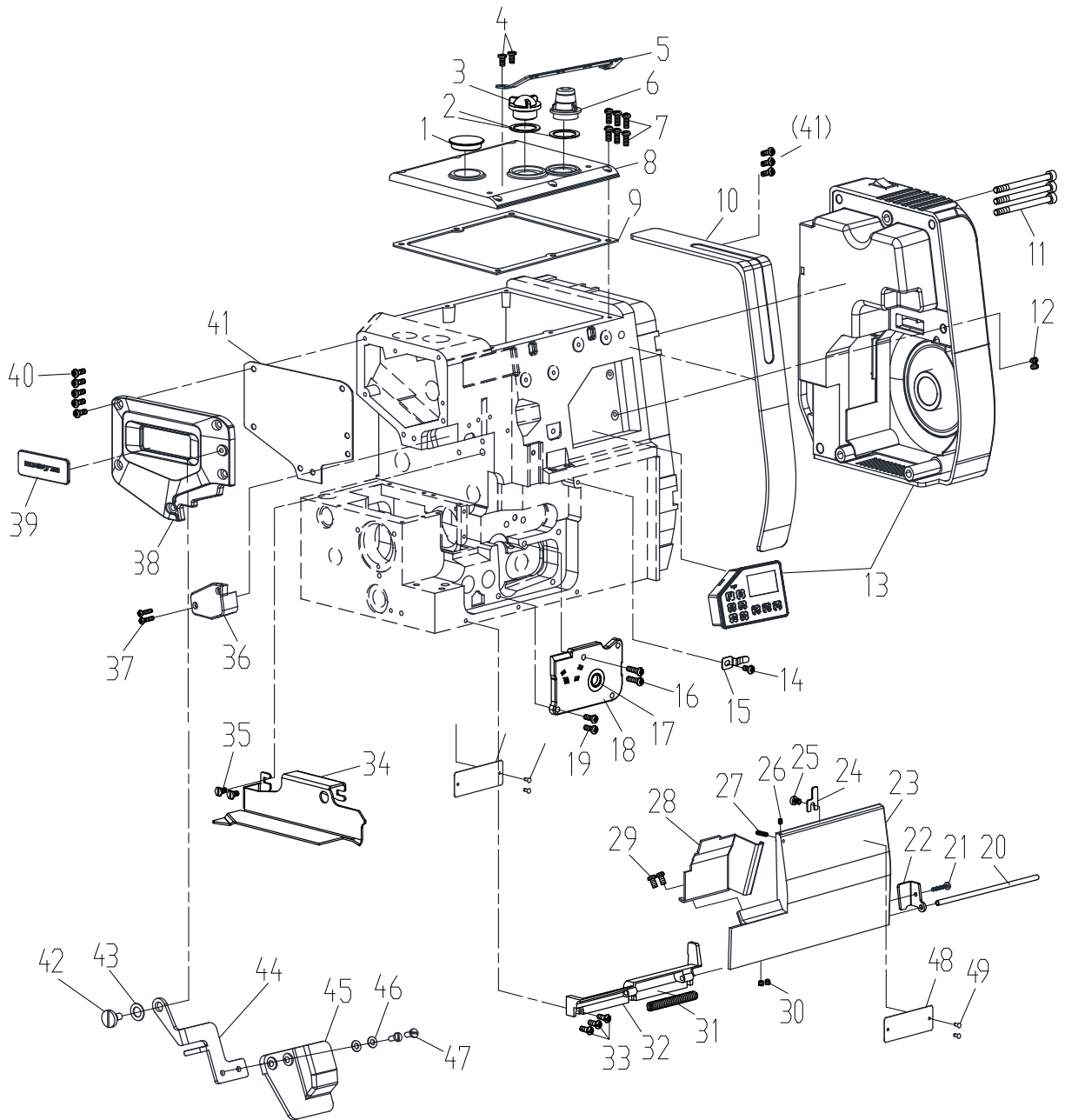

## 2. 外罩部件 (1) /OUT COVER FRAME (1)

序号 No.	件号 Parts No.	名称	Description	数量 QT.
1	10045754	橡胶塞	rubber plug	1
2	10009156	油窗橡胶圈	oil window rubber ring	2
3	10008938	油窗	oil window	1
4	10010554	螺钉	screw	2
5	10063871	过线架	a wire frame	1
6	10062483	油窗	oil window	1
7	10009104	螺钉	screw	6
8	20023697	上盖	upper cover	1
9	10062480	上盖密封垫	seal cushion for upper cove	1
10	10062489	装饰条	trim strip	1
11	10053560	螺钉	screw	3
12	10003150	螺钉	screw	2
13	☆	简易电控	simple electronic control	1
14	10004171	螺钉	screw	1
15	10033682	弹簧板	spring plate	1
16	10008965	螺钉	screw	2
17	10009399	油封	oil seal	1
18	10008917	上弯针架盖	cover for upper looer stand	1
19	10011044	螺钉	screw	2
20	10062485	销	pin	1
21	10063870	螺钉	screw	1
22	10008911	导向板	guiding plate	1
23	20023695	前盖右	right part of the front cover	1
24	10059247	前盖右挡板	fender for right part of front cover	1
25	10004171	螺钉	screw	1
26	10013019	螺钉	screw	1
27	10009550	螺钉	screw	1
28	10062482	前盖中	midle part of the front cover	1
29	10010554	螺钉	screw	2
30	10023463	螺钉	screw	2
31	10009509	弹簧	spring	1
32	10008880	支架	supporrting part	1
33	10009037	螺钉	screw	3
34	10008920	内盖板	the cover plate	1
35	10009157	螺钉	screw	2
36	10064191	B9500机头灯	head lamp	1
37	10013938	螺钉	screw	2
38	20023696	侧盖	side cover	1
39	10062054	面板装饰牌	decoratire plate	1
40	10010594	螺钉	screw	8
41	10062593	侧盖密封垫	side gasket	1
42	10009044	螺钉	screw	1
43	10010596	垫圈	washer	1
44	10062486	护板支架	support plate	1
45	10008878	安全罩	safety cover	1
46	10009599	垫圈	washer	2
47	10009600	螺钉	screw	2
48	10064204	型号牌	date of the card	1
49	10002840	铆钉	rivet	2

3. 外罩部件 (2) / OUT COVER FRAME (2)

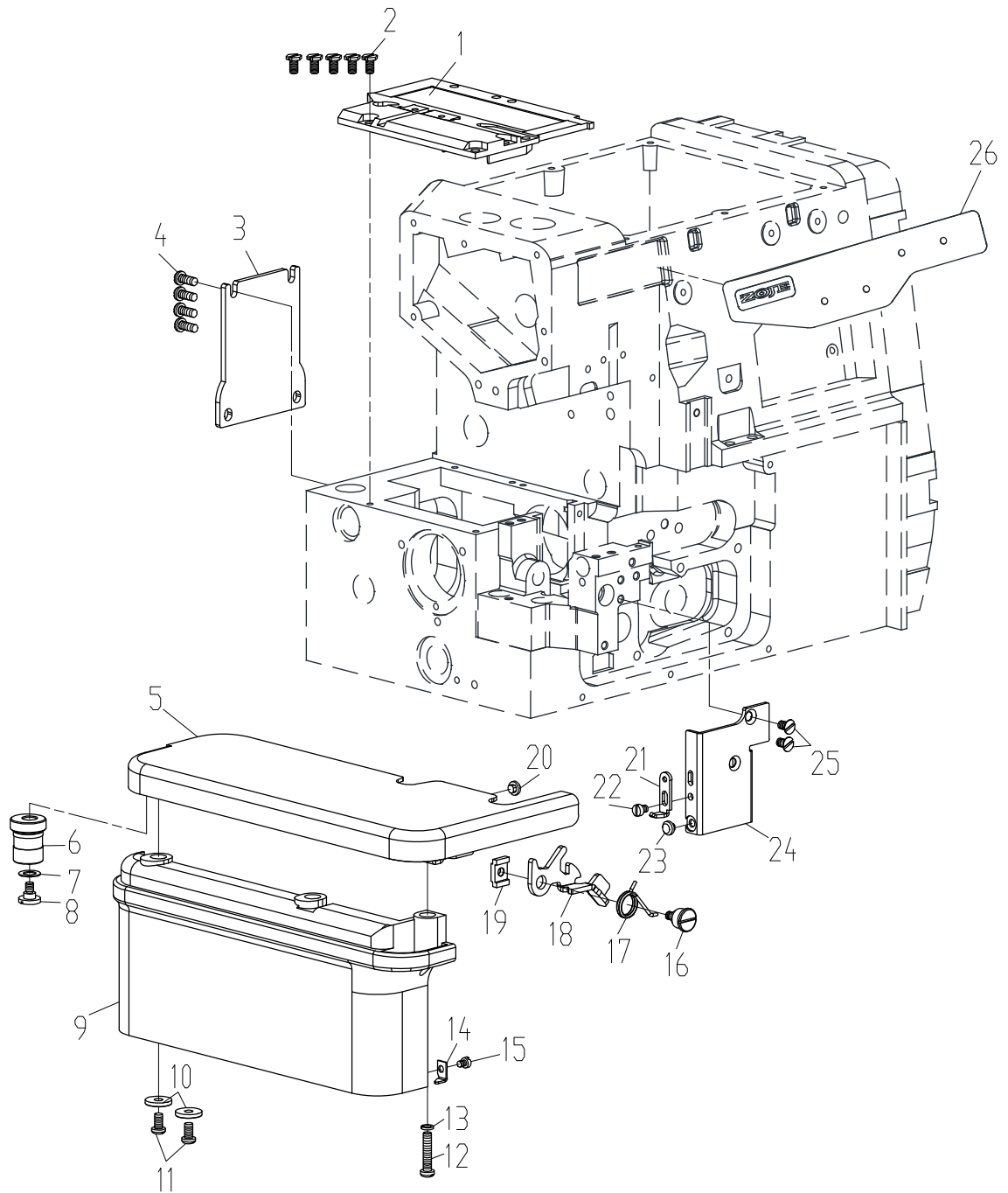

### 3. 外罩部件 (2) /OUT COVER FRAME (2)

序号 No.	件号 Parts No.	名称	Description	数量 QT.
1	10058546	左上盖	left upper cover	1
2	10009157	螺钉	screw	5
3	10033690	后盖板组件	comp on ent of back cover	1
4	10009104	螺钉	screw	4
5	10008967	大盖组件	component of surface cover	1
6	10009547	大盖铜套	brass bush for surface cover	1
7	10010596	垫圈	washer	1
8	10009044	螺钉	screw	1
9	10009450	横盖组件	lower left side cover	1
10	10009537	垫圈	washer	2
11	10010595	螺钉	screw	2
12	10009291	螺钉	screw	1
13	10008144	垫圈	washer	1
14	10033700	横盖限位板	position limiting plate	1
15	10009529	螺钉	screw	1
16	10009546	螺钉	screw	1
17	10009536	弹簧	spring	1
18	10009535	大盖卡紧板	grip part for surface cover	1
19	10009548	锁紧板	locking plate	1
20	10037505	防震橡胶垫	quake-proof rubber cushion	1
21	10033689	挡板	baffle	1
22	10009514	螺钉	screw	1
23	10037505	防震橡胶垫	quake-proof rubber cushion	1
24	10008882	前盖左	left part of front cover	1
25	10009514	螺钉	screw	2
26	10063873	独立LOGO灯组件	independnet logo lamp cover	1

#### 4. 三自动部件/ THREE AUTOMATIC FRAME

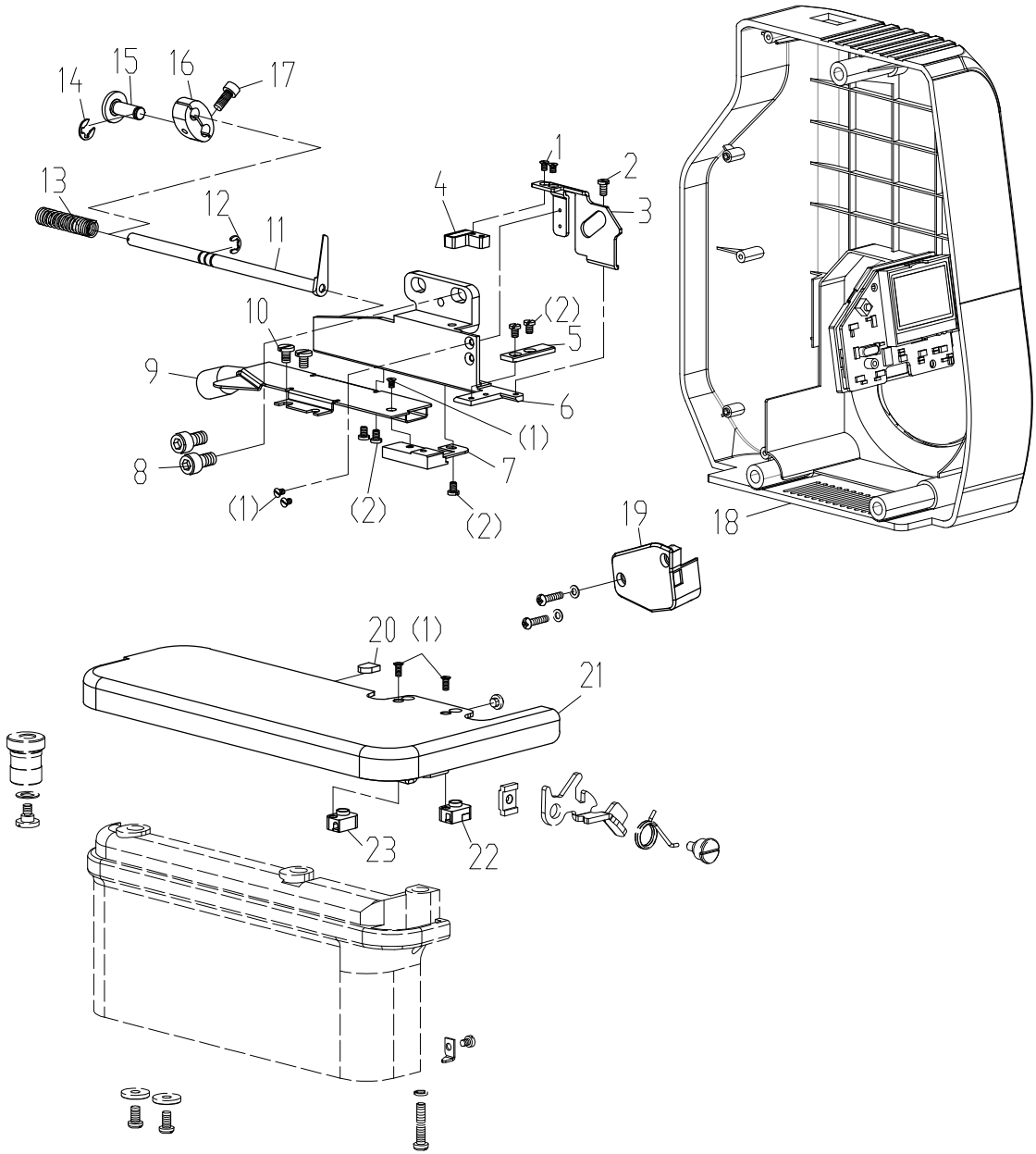



#### 4. 三自动部件/THREE AUTOMATIC FRAME

序号 No.	件号 Parts No.	名称	Description	数量 QT.
1	10009379	螺钉	screw	7
2	10038921	螺钉	screw	6
3	10058568	压脚安全开关固定板	guiding plate for safety switch presser foot	1
4	10059012	压脚安全开关组件	safety switch component of the presser foot	1
5	10037797	定刀	stationary knife	1
6	10037460	拖布轮剪刀固定架	mount of cutter	1
7	10059003	后切接收传感器	sensor component of receivering the back cut	1
8	10003169	螺钉	screw	2
9	10037456	拖布轮内盖板 (ED2)	the cover plate	1
	10037457	吸风管组件 (ED3)	component of aspirration	1
10	10014441	螺钉	screw	2
11	10038985	动刀	moving cutter	1
12	10025649	开口挡圈	split washer	1
13	10025648	弹簧	spring	1
14	10013038	开口挡圈	split washer	1
15	10037477	切刀连杆销	pin for connecting rod of cutter	1
16	10037475	切刀连杆	connecting rod of cutter	1
17	10012752	螺钉	screw	1
18	☆	三自动电控	automatic electric control	1
19	10062787	发射传感器组件	sensor component for emitter	1
20	10037469	缝台安全开关磁铁	magnet	1
21	10058548	大盖组件	component of surface cover	1
22	10058571	抬压脚接收传感器组件	sensor cpmponent of the lifting presser foot	1
23	10059002	前切接收传感器组件	receiver component for front cut	1

5. 主轴机构/ MAIN SHAFT MECHANISM

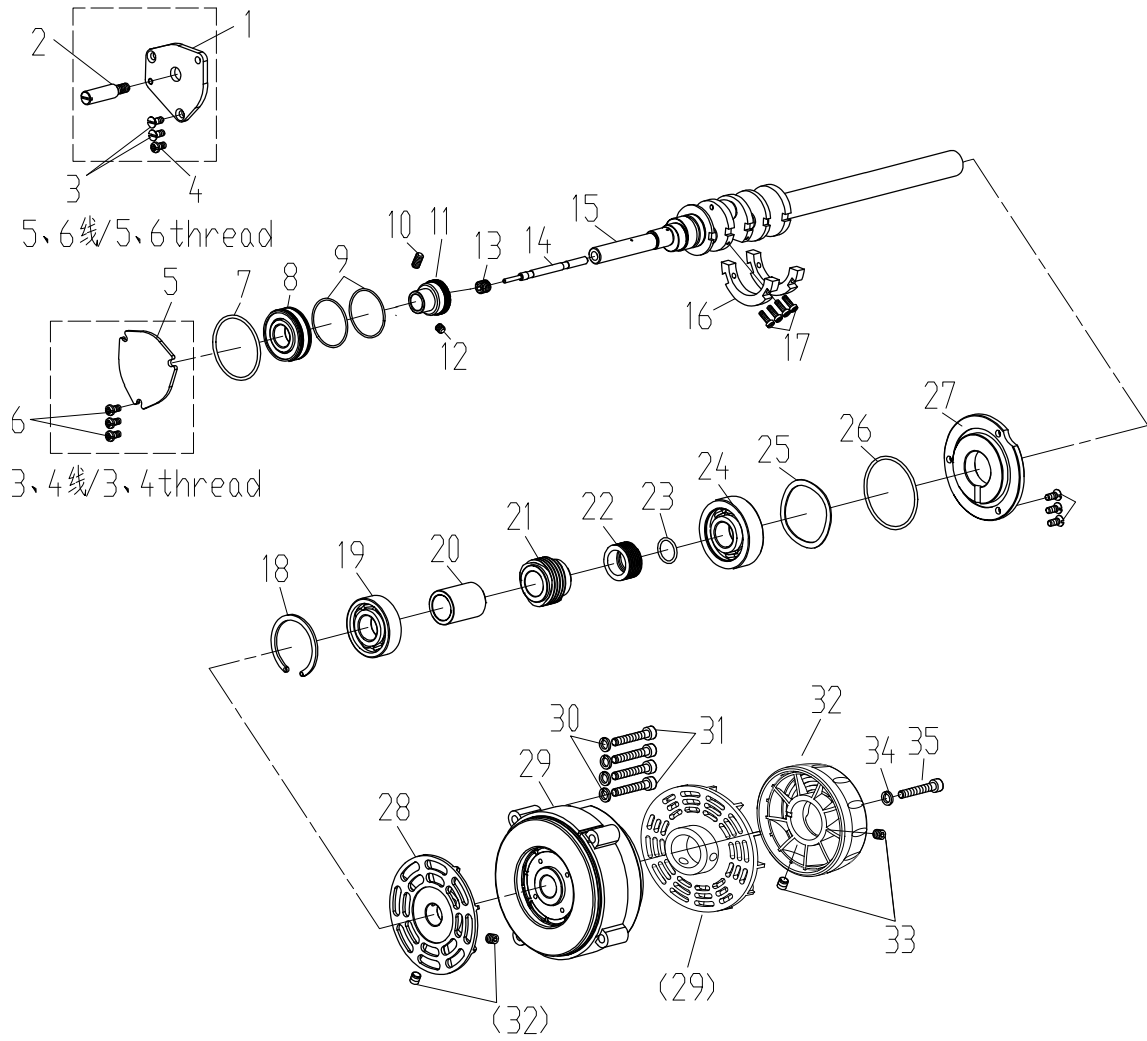

## 5. 主轴机构/MAIN SHAFT MECHANISM

序号 No.	件号 Parts No.	名称	Description	数量 QT.
1	10009643	左盖	left cover	1
2	10007842	螺钉	screw	1
3	10009195	螺钉	screw	5
4	10009104	螺钉	screw	1
5	10009519	左盖	left cover	1
6	10010595	螺钉	screw	3
7	10009448	O型圈	O ring	1
8	10025895	6202N2-RZ_BOM轴承	bearing	1
9	10009334	O型圈	O ring	2
10	10012162	螺钉	screw	1
11	10002966	轴承套	bush mounted in bearing	1
12	10009167	螺钉	screw	1
13	10009187	螺钉	screw	1
14	10009479	主轴轴芯	the spindle axis core	1
15	10058553	主轴(普通料机械)	main shaft(general machine)	1
	10058550	主轴(厚料机械)	main shaft(heavy machine)	1
16	10009402	平衡块	balance block	1
17	10003001	螺钉	screw	4
18	10008898	主轴卡圈	main shaft retainer ring	1
19	10009780	6203轴承	bearing	1
20	10009392	蜗杆套	bush mounted in worm bush	1
21	10009362	蜗杆	wrom bush	1
22	10055917	螺纹套	bush mounted in screw	1
23	10009360	O型圈	O ring	1
24	10055926	6303V轴承BOM	bearing	1
25	10055918	右盖垫片	spring washer	1
26	10055919	O型圈	O ring	1
27	10055920	右盖	right cover	1
28	10059605	风扇	fan	1
29	10059606	电机组件	motor	1
30	10005537	垫圈	washer	4
31	10001497	螺钉	screw	4
32	10058555	手轮组件	hand wheel assembly	1
33	10003151	螺钉	screw	4
34	10003249	垫圈	washer	1
35	10001901	螺钉	screw	1

6. 线张力调节机构/ THREAD TENSION MECHANISM

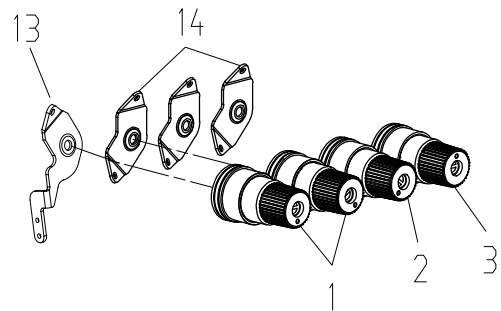
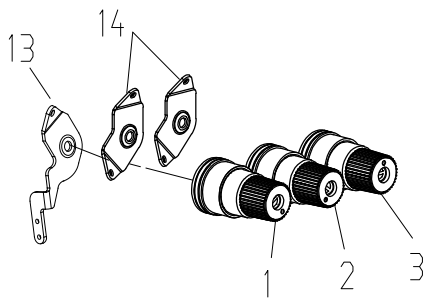
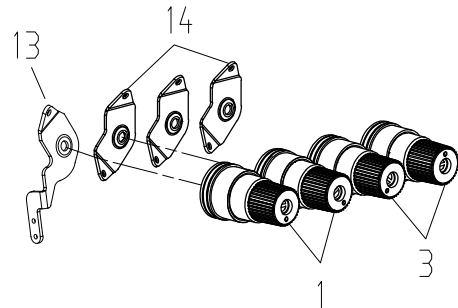
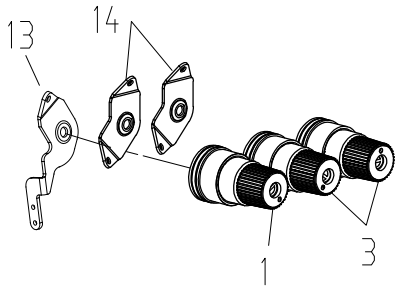
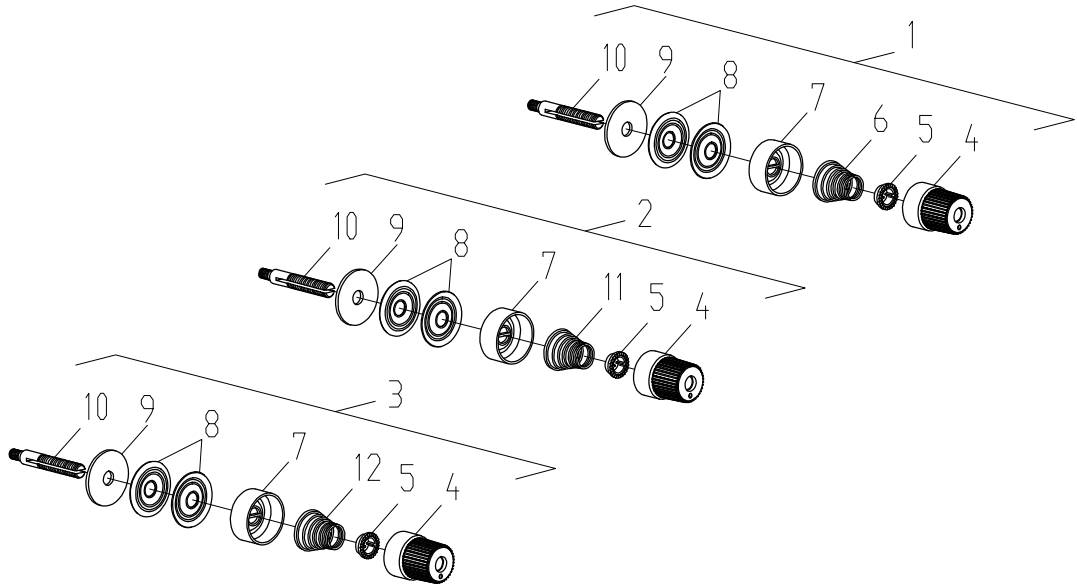

## 6. 线张力调节机构/THREAD TENSION MECHANISM

序号 No.	件号 Parts No.	名称	Description	数量 QT.
1	10058522	直针夹线器组件	thread tension aggregate for needle	1
2	10058523	上弯针夹线器组件	thread tension aggregate for upper needle	1
3	10058524	下弯针夹线器组件	thread tension aggregate for lower needle	1
4	10058521	夹线螺母	thread tension nut	1
5	10003111	防松垫	release-proof nut	1
6	10009534	弹簧	spring	1
7	10058520	夹线碗	thread tension bowl	1
8	10003116	夹线盘	thread tension dish	2
9	10009010	布垫	cloth cushion	1
10	10003112	螺钉	screw	1
11	10009532	弹簧	spring	1
12	10009533	弹簧	spring	1
13	10062470	二孔过线板	thread guide plate with two hole	1
14	10057503	过线版	thread guide plate	3

7. 针杆传动机构(1) / NEEDLE DRIVE MECHANISM(1)

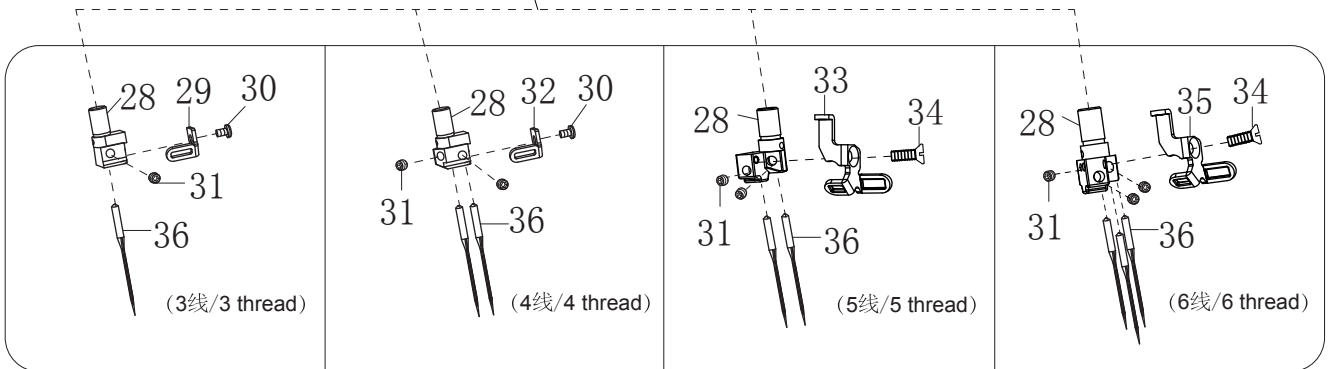
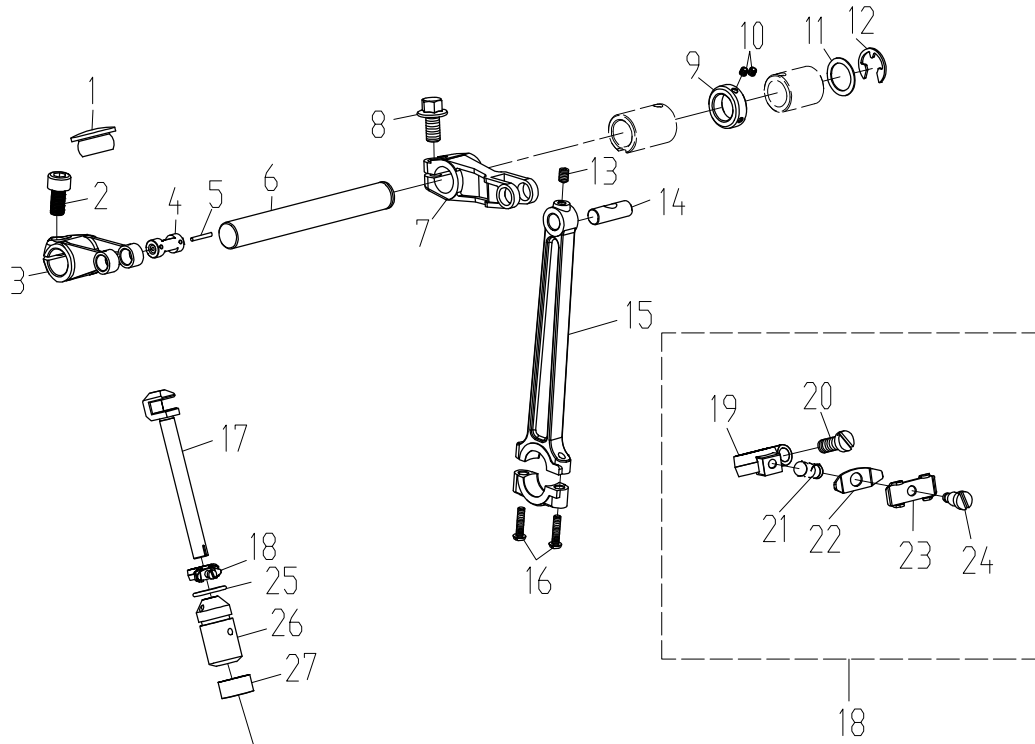

7. 针杆传动机构(1)/NEEDLE DRIVE MECHANISM(1)				
序号 No.	件号 Parts No.	名称	Description	数量 QT.
1	10009576	橡胶塞	rubber plug	1
2	10009245	螺钉	screw	1
3	10009374	直针曲柄	crank on needle bar	1
4	10009345	直针曲柄销	crank pin for needle bar	1
5	10008090	油线	oil wick	1
6	10009423	针杆传动轴	driving shaft for needle bar	1
7	10009433	针杆传动曲柄	crank on needle bar drive shaft	1
8	10009164	螺钉	screw	1
9	10009357	挡圈	retaining ring	1
10	10009074	螺钉	screw	2
11	10033718	垫圈	washer	1
12	10003273	挡圈	retaining ring	1
13	10009109	螺钉	screw	1
14	10009432	直针连杆销	pin for connecting rod	1
15	10002961	直针传动连杆	connecting rod for needle bar	1
16	10002939	螺钉	screw	2
17	10009386	针杆	needle bar	1
18	20001229	针夹头夹组件	the needle clamp clip	1
19	10009344	针夹头夹	the needle clamp clip	1
20	10010888	螺钉	screw	1
21	10009400	夹线簧	spring	1
22	10009341	下夹线板	lower thread tension plate	1
23	10009386	上夹线板	upper thread tension plate	1
24	10009383	螺钉	screw	1
25	10009391	O型圈	O ring	1
26	10009401	针杆套	needle bar bush	1
27	10009356	针杆套毛毡	felt	1
28	*	针夹头	needle holder	1
29	10003431	针夹头过线板	thread guide plate of needle holder	1
30	10009422	螺钉	screw	1
31	10009255	螺钉	screw	*
32	10009339	针夹头过线板	thread guide plate of needle holder	1
33	10009644	针夹头过线板	thread guide plate of needle holder	1
34	10009664	螺钉	screw	1
35	10008205	针夹头过线板	thread guide plate of needle holder	1
36	*	机针	needle	1
*:参看专用件表/see the guage list				

8. 针杆传动机构(2) / NEEDLE DRIVE MECHANISM(2)

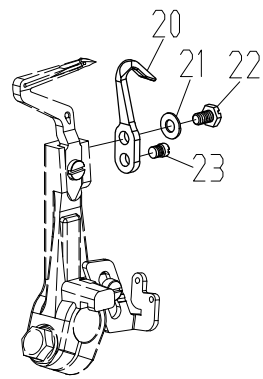
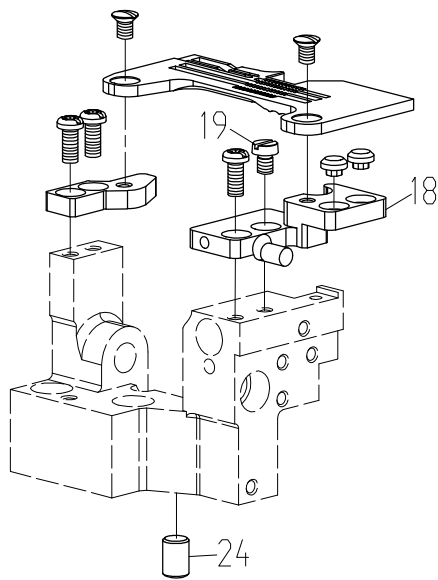
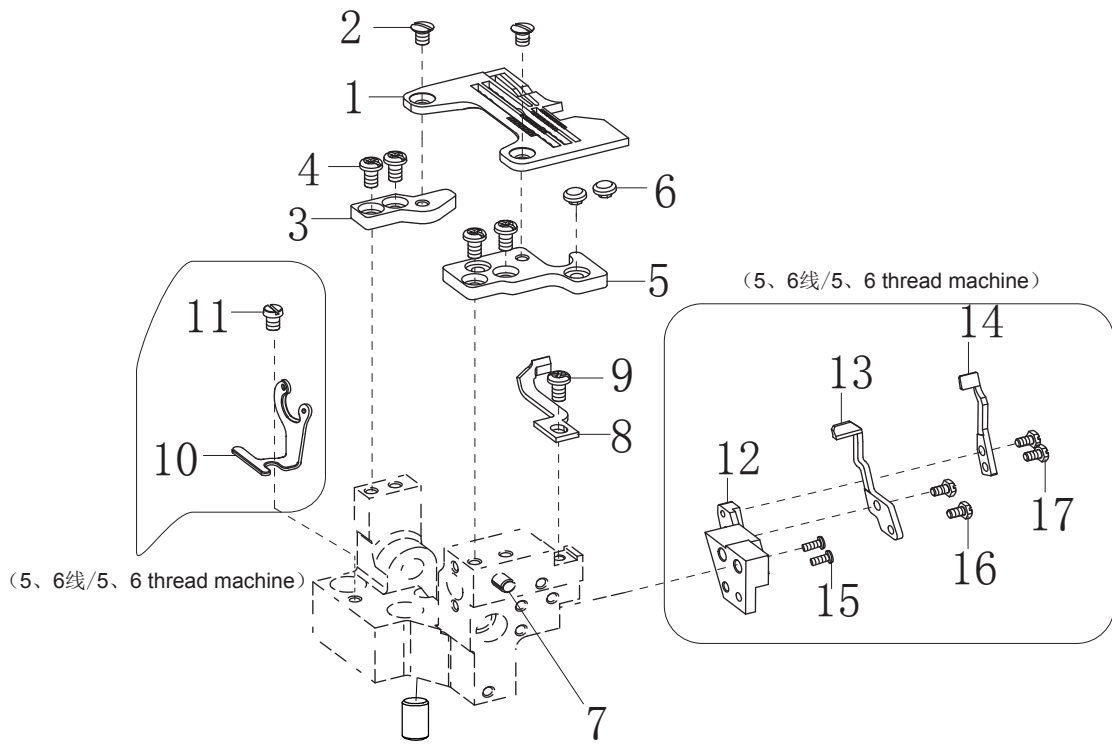



## 8. 针杆传动机构(2)/NEEDLE DRIVE MECHANISM(2)

序号 No.	件号 Parts No.	名称	Description	数量 QT.
1	*	针板	needle plate	1
2	10009290	螺钉	screw	2
3	10009354	针板托	needle plate support	1
4	10010595	螺钉	screw	4
5	10009420	针板座	base of needle guard	1
6	10061231	防震橡胶垫	rubber cushion	2
7	10012905	销	pin	1
8	10009377	直针前护针架(3、4线)	front needle guard(3、4thread machine)	1
	10009637	直针前护针架(5、6线)	front needle guard(5、6thread machine)	1
9	10010595	螺钉	screw	1
10	10040242	链弯针前过线板	frent thread guide	1
11	10004171	螺钉	screw	1
12	10009306	护针座	needle guard barcket	1
13	10009636	链弯针后护针	rear needle guard	1
14	10009657	链弯针前护针	front needle guard	1
15	10009638	螺钉	screw	2
16	10010555	螺钉	screw	2
17	10010555	螺钉	screw	2
18	10058562	针板座	base of needle guard	1
19	10010554	螺钉	screw	1
20	10009023	直针后护针	rear needle guard	1
21	10003274	垫圈	washer	1
22	10009021	螺钉	screw	1
23	10009020	螺钉	screw	1
24	10009048	销	pin	1
		*:参看专用件表/see the guage list		

9. 上弯针传动机构/ UPPER LOOPER DRIVE MECHANISM

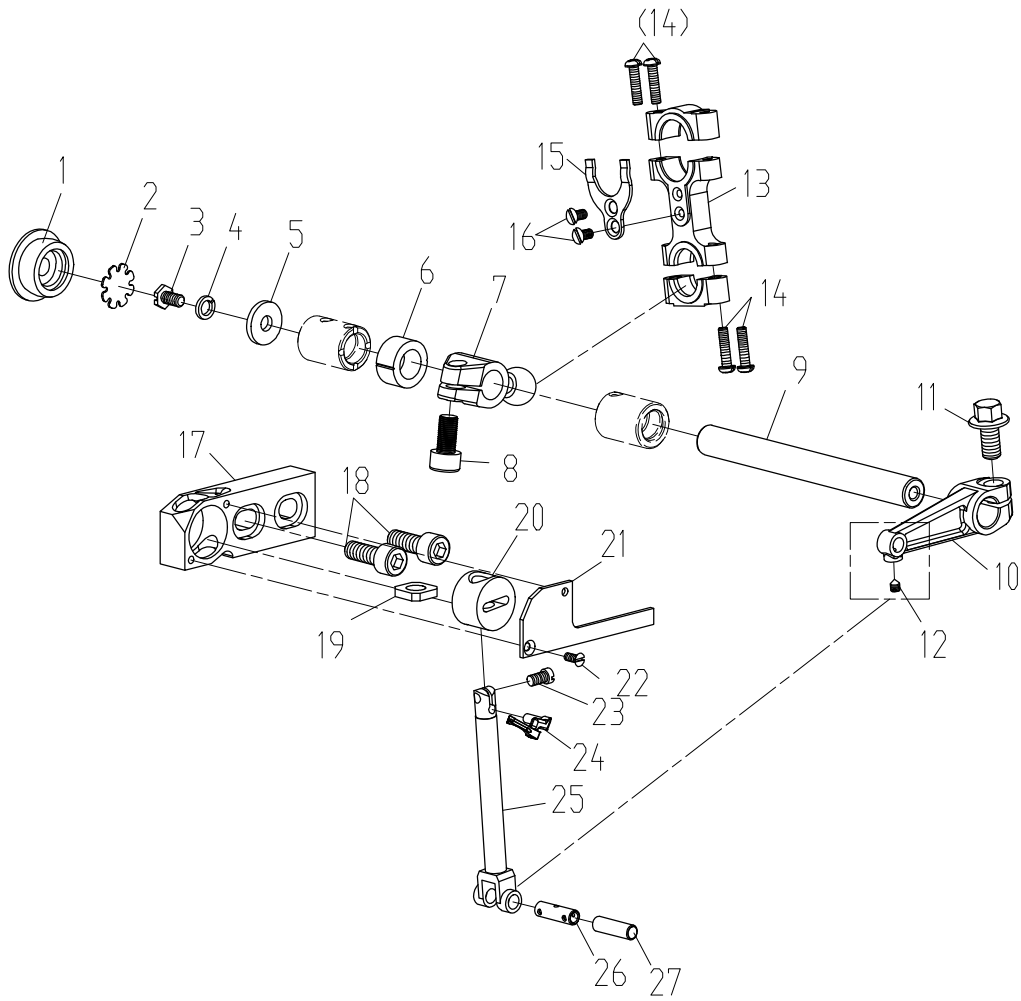

## 9. 上弯针传动机构/UPPER LOOPER DRIVE MECHANISM

序号 No.	件号 Parts No.	名称	Description	数量 QT.
1	10039396	橡皮塞	rubber plug	1
2	10039397	挡油架	oil baffle frame	1
3	10009349	螺钉	screw	1
4	10005537	垫圈	washer	1
5	10033711	垫圈	washer	1
6	10009338	挡圈	retaining ring	1
7	10003062	上弯针球曲柄	crank bush with ball head for upper looper	1
8	10009164	螺钉	screw	1
9	10009404	上弯针轴	drive shaft for upper looper	1
10	10009373	上弯针摇杆	swing bar for upper looper shaft	1
11	10009245	螺钉	screw	1
12	10009240	螺钉	screw	1
13	10003064	弯针传动连杆	connecting bar for upper looper drive	1
14	10002939	螺钉	screw	4
15	10009431	连杆挡板	fender for connecting bar	1
16	10009626	螺钉	screw	1
17	10002912	滑杆座	sliding bar bracket	1
18	10009008	螺钉	screw	2
19	10009405	毛毡	felt	1
20	10002905	滑杆套	sliding bar bush	1
21	10009370	盖板	cover plate	1
22	10009379	螺钉	screw	1
23	10013969	螺钉	screw	1
24	*	上弯针	upper looper	1
25	10002913	滑杆	sliding bar	1
26	10009406	销	pin	1
27	10008067	油线	oil wick	1
		*:参看专用件表/see the gauge list		

10. 下弯针机构/ LOWER LOOPER MECHANISM

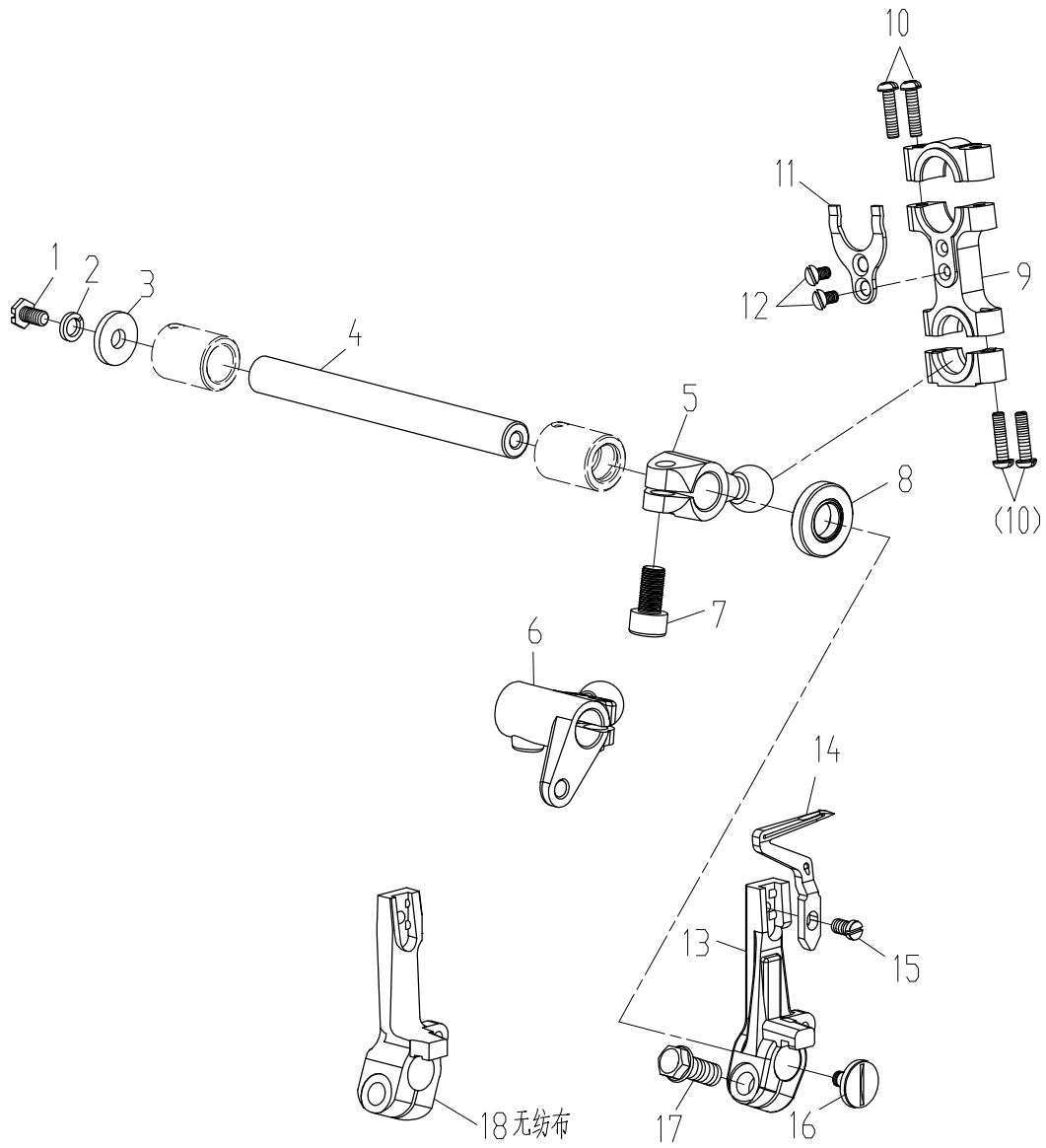



# 11. 链弯针机构/ CHAIN STITCH LOOPER FRAME

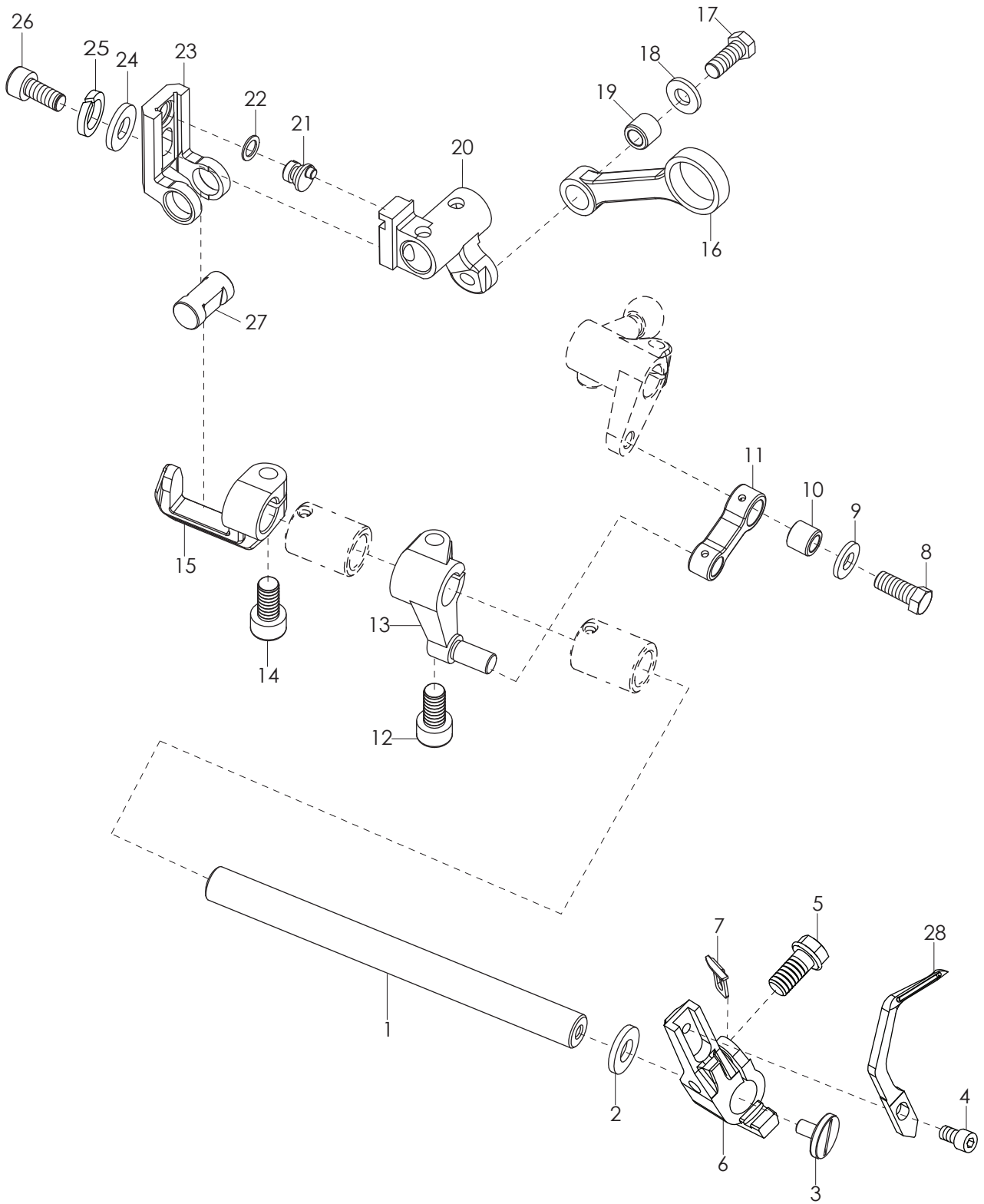

## 11. 链弯针机构/CHAIN STITCH LOOPER MECHANISM

序号 No.	件号 Parts No.	名称	Description	数量 QT.
1	10009309	链弯针轴	shaft for chain stitch looper	1
2	10009071	密封圈	seal ring	1
3	10009394	螺钉	screw	1
4	10010643	螺钉	screw	2
5	10009310	螺钉	screw	2
6	10009307	链弯针架	stand of chain stitch looper	1
7	10003294	挡片	blocking ring	1
8	10009142	螺钉	screw	2
9	10009192	垫圈	washer	1
10	10023487	连杆销套	needle pin for connecting bar	1
11	10009186	送料连杆	connecting bar of feed dog	1
12	10009245	螺钉	screw	1
13	10009302	摆动曲柄	swing crank	1
14	10009245	螺钉	screw	1
15	10009305	摆动叉	swing fork	1
16	10047854	链弯针传动连杆	connecting bar for chain stitch looper	1
17	10009142	螺钉	screw	1
18	10009192	垫圈	washer	1
19	10023487	连杆销套	needle pin for connecting bar	1
20	10009308	调节曲柄	crank of regulator	1
21	10009311	偏心销	pin	1
22	10009641	O型圈	O ring	1
23	10009303	调节座	base of regulator	1
24	10009192	垫圈	washer	1
25	10005537	垫圈	washer	1
26	10014210	螺钉	screw	1
27	10034624	调节杆轴	shaft of adjusting bar	1
28	*	链弯针	chain stitch looper	1
		*:参看专用件表/see the gauge list		

## 12. 打线凸轮机构 / CAM ASSEMBLY

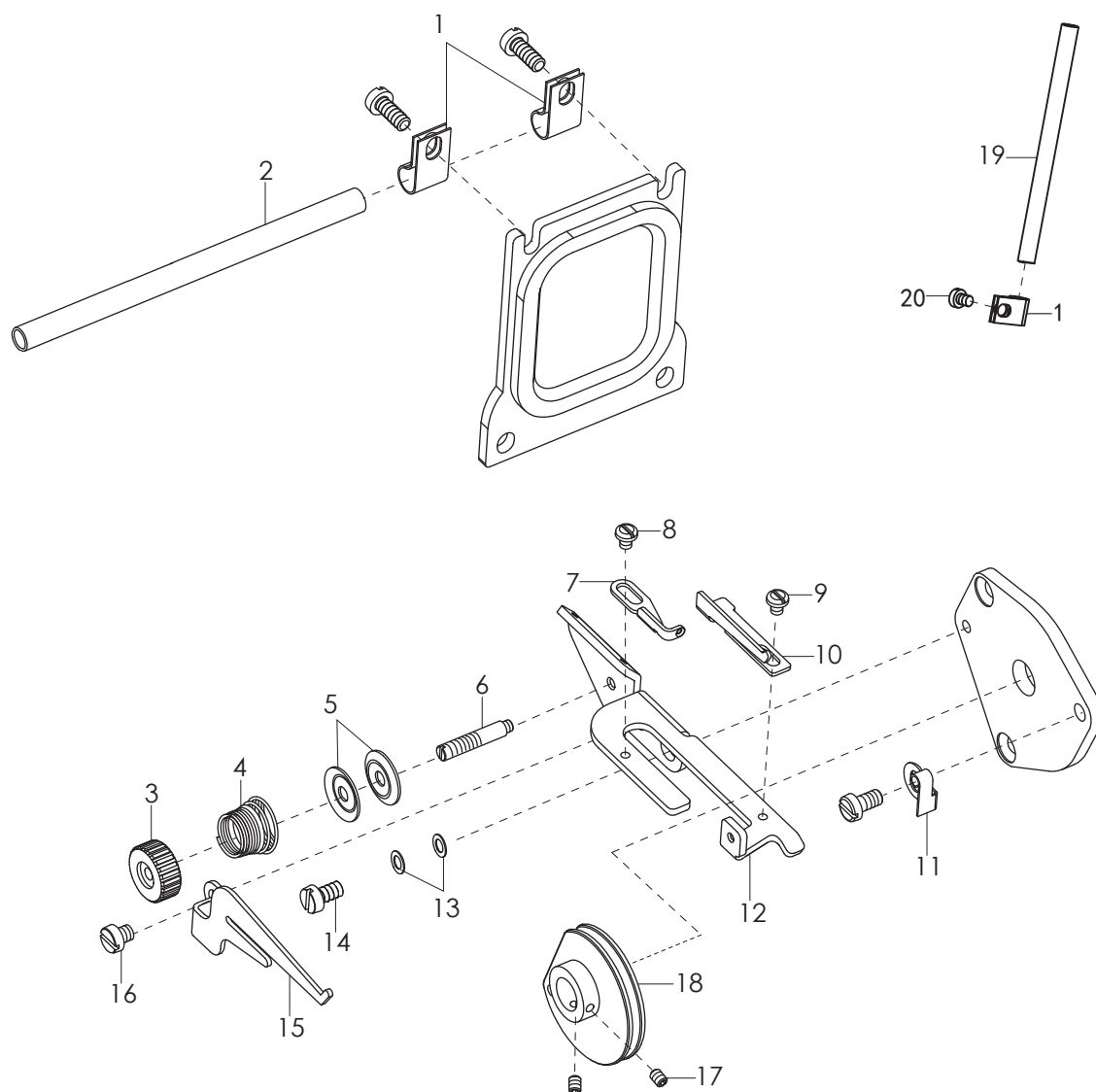



## 12. 打线凸轮部件/CAM ASSEMBLY

序号 No.	件号 Parts No.	名称	Description	数量 QT.
1	10010693	过线管夹簧	elastic clamp for thread guide	3
2	10009283	横过线管	horizontal thread guide pipe	1
3	10010609	夹线螺母	thread tension nut	1
4	10010612	弹簧	spring	1
5	10010613	夹线板	thread tension dish	2
6	10010610	螺钉	screw	1
7	10010654	过线架	thread guide plate	1
8	10009529	螺钉	screw	1
9	10009529	螺钉	screw	1
10	10010614	过线板	thread guide plate	1
11	10010596	垫圈	washer	1
12	10010611	过线架	thread tension stand	1
13	10010596	垫圈	washer	2
14	10010556	螺钉	screw	1
15	10033740	打线架	thread take-up stand	1
16	10004171	螺钉	screw	1
17	10010664	打线凸轮组件	thread take-up cam assembly	1
18	10010196	螺钉	screw	2
19	10009285	竖过线管	the vertical line pipe	1
20	10009556	螺钉	screw	1

13. 差动送布机构(1) / DIFFERENTIAL FEED ASSEMBLY(1)

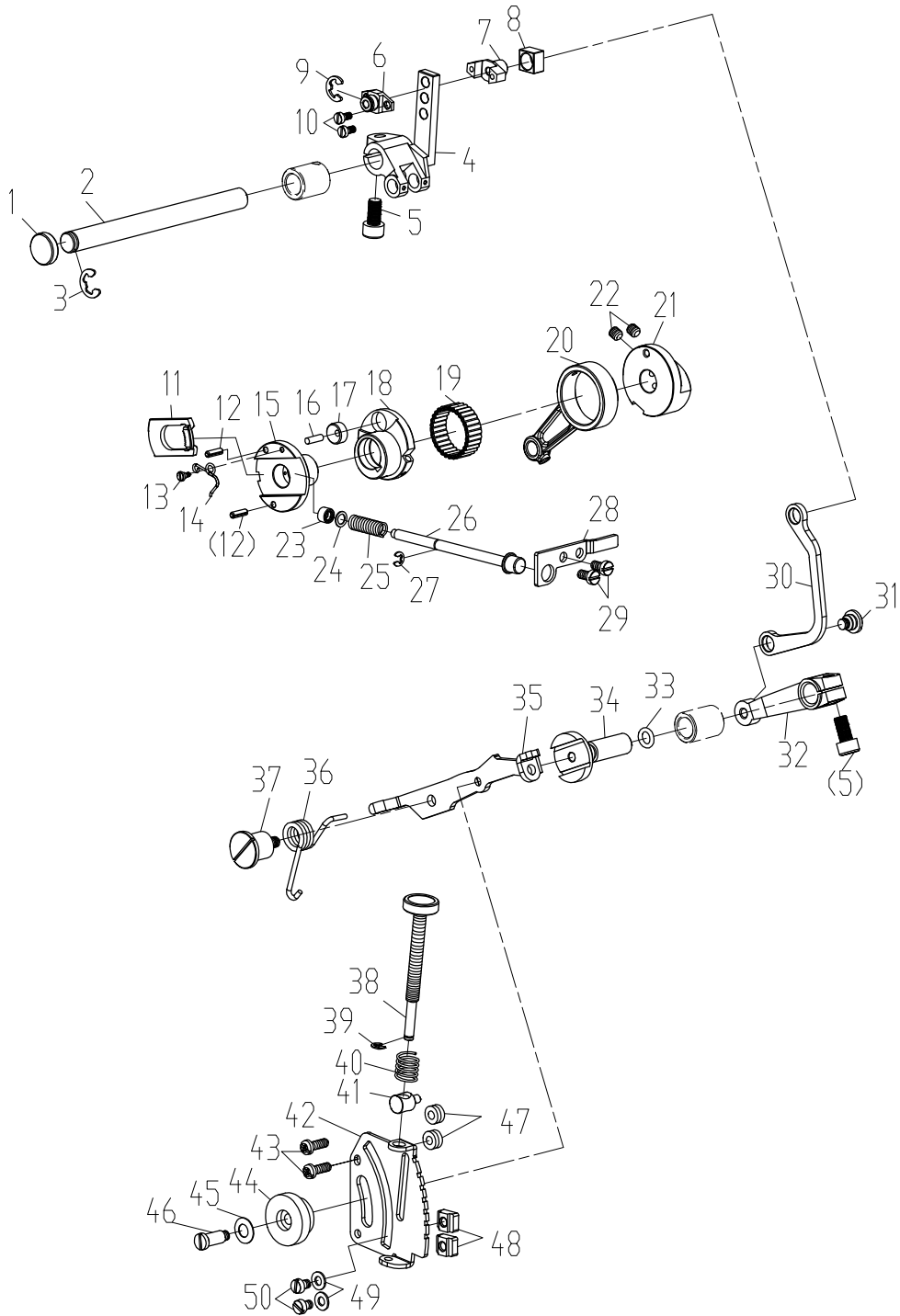

### 13. 差动送布机构(1)/DIFFERENTIAL FEED ASSEMBLY(1)

序号 No.	件号 Parts No.	名称	Description	数量 QT.
1	10008961	橡胶塞	rubber plug	1
2	10009198	送料轴	feeding shaft	1
3	10009239	挡圈	retaining spring	1
4	10002593	差动调节右曲柄	right crank of differential regulator	1
5	10009164	螺钉	screw	2
6	10002591	曲柄滑槽盖	crank slide troligh cover	1
7	10002592	曲柄滑槽	crank slide troligh	1
8	10009139	差动牙架滑块	sliding block	1
9	10008989	挡圈	rataining spring	1
10	10009625	螺钉	screw	2
11	10012162	内齿锁紧块	sliding block with inner teeth	1
12	10009298	销	Pin	2
13	10002890	螺钉	screw	1
14	10002887	扭簧	spring	1
15	10002885	针距调节凸轮	adjusting cam for stitch length	1
16	10003219	销	pin	1
17	10003218	送布偏心轮导轮	guiding wheel of feeding eccevtric wheel	1
18	10009327	送布偏心轮	feeding eccentric wheel	1
19	10002888	轴承	bearing	1
20	10002946	滚针轴承连杆	connecting bar	1
21	10002977	针距调节偏心轮片	eccentric wheel of stitch length regulator	1
22	10012162	螺钉	screw	2
23	10053036	针距按钮轴密封圈	oil seal	1
24	10009246	垫圈	washer	1
25	10009248	针距按钮轴弹簧	spring	1
26	10009249	针距调节按钮轴	button shaft	1
27	10003248	挡圈	retaining spring	1
28	10009040	针距按钮挡板	plate	1
29	10010595	螺钉	screw	2
30	10009000	差动调节连杆	differential regulating connecting rod	1
31	10009624	螺钉	screw	1
32	10009256	差动调节左曲柄	left crank of differential regulator	1
33	10009608	O型圈	O ring	1
34	10034607	差动调节轴	shaft of differential regultor	1
35	10009224	调节杆	adjusting bar	1
36	10009563	扭簧	spring	1
37	10009558	螺钉	screw	1
38	10009218	微调螺柱	screw	1
39	10003248	挡圈	retaining spring	1
40	10009205	弹簧	spring	1
41	10009203	螺母	nut	1
42	10009223	调节指示板	indication plate of adjustment	1
43	10009037	螺钉	screw	2
44	10009565	螺母	nut	1
45	10009564	垫片	washer	1
46	10009562	螺钉	screw	1
47	10009200	垫圈	washer	2
48	10009221	限位块	position plate	2
49	10003083	垫片	washer	2
50	10010554	螺钉	screw	2

14. 差动送布机构(2) / DIFFERENTIAL FEED ASSEMBLY(2)

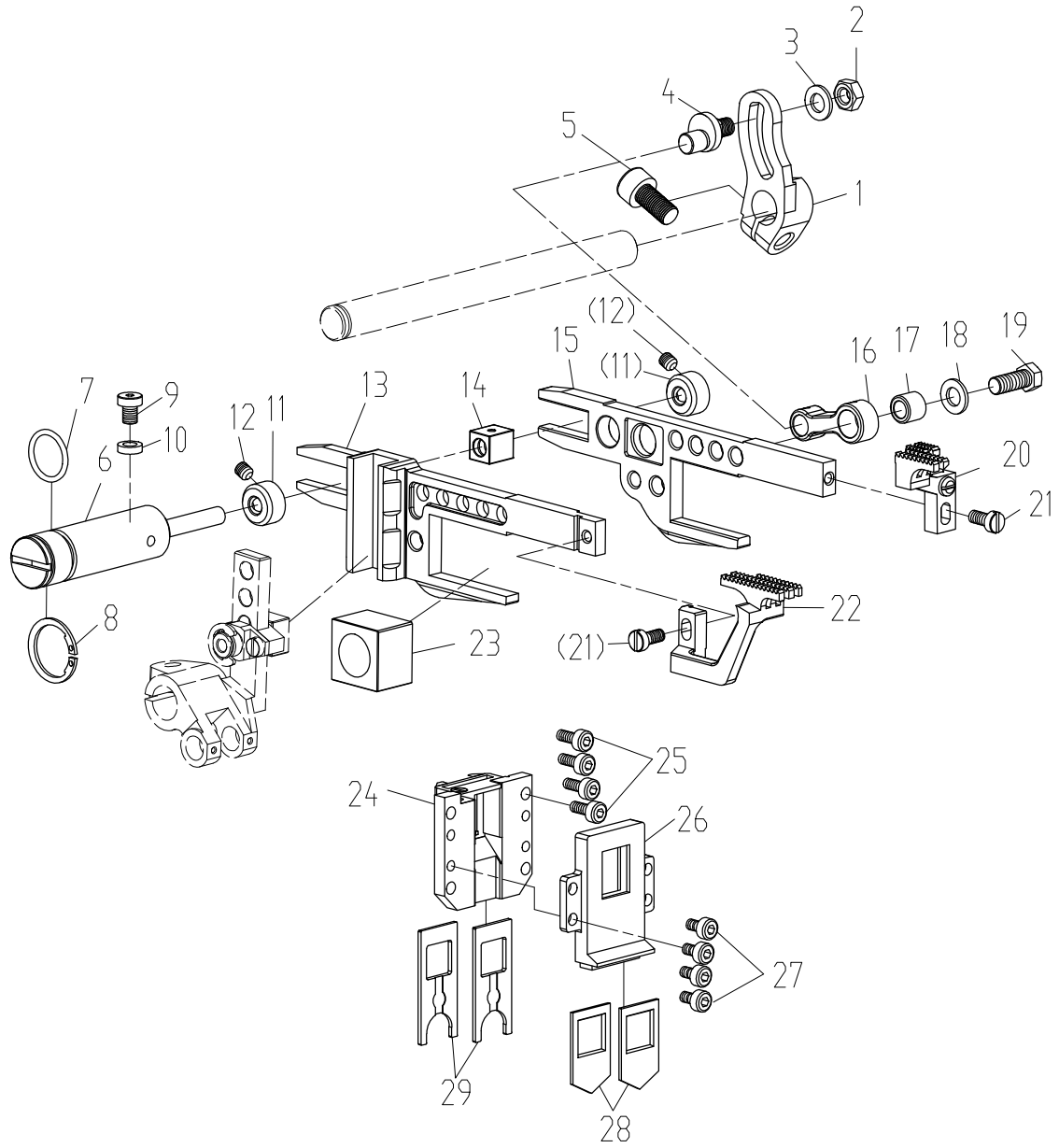

### 14. 差动送布机构(2)/DIFFERENTIAL FEED ASSEMBLY (2)

序号 No.	件号 Parts No.	名称	Description	数量 QT.
1	10009194	方口曲柄	crank with rectangular shaft	1
2	10009467	螺母	nut	1
3	10009192	垫圈	washer	1
4	10009193	送料连杆销	pin with thread for feeding connecting rod	1
5	10009164	螺钉	screw	1
6	10009137	抬牙调节偏心轴	eccentric shaft	1
7	10009135	O型圈	O ring	1
8	10009136	挡圈	spring	1
9	10009117	偏心轴锁紧螺钉	screw	1
10	10009114	偏心轴锁紧螺钉橡胶垫	rubber cushion	1
11	10009166	挡圈	washer	1
12	10009074	螺钉	screw	1
13	10009140	差动牙架	stand of differential feed dog	1
14	10009134	抬牙调节滑块	sliding block	1
15	10009141	送料牙架	stand of feed dog	1
16	10066197	送料连杆	feeding connecting rod	1
17	10023487	连杆销套	bush connecting rod	1
18	10009192	垫圈	washer	1
19	10009142	螺钉	screw	1
20	*	主送料牙组件	body of main feed dog	1
21	10009586	螺钉	screw	2
22	*	差动送料牙	differential feed dog	1
23	10009133	抬牙滑块	sliding block for feed dog lifting	1
24	10036169	牙架导板组件	guiding plate of feed dog stand	1
25	10009102	螺钉	screw	4
26	10009161	外油封架	outer oil seal stand	1
27	10002975	螺钉	screw	4
28	10009081	牙架油封	oil seal	2
29	10037823	牙架油封	oil seal	2
		*:参看专用件表/see the gauge list		

15. 切料机构/ KNIFE DRIVE ASSEMBLY

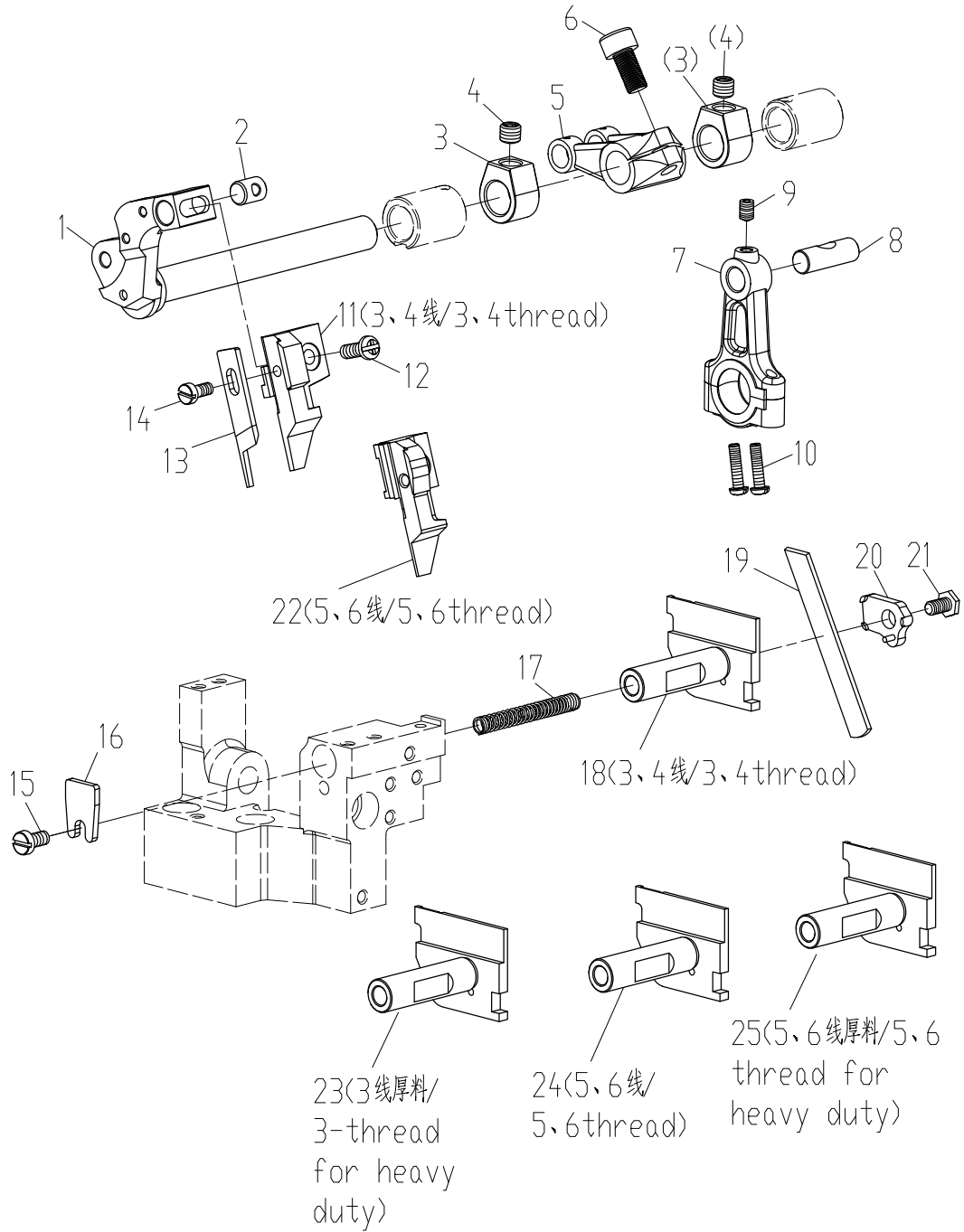

### 15. 切料机构/KNIFE DRIVE ASSEMBLY

序号 No.	件号 Parts No.	名称	Description	数量 QT.
1	10037470	上刀轴	shaft of upper knife drive	1
2	10009070	上刀架紧固销	fastening pin for upper knife holder	1
3	10009078	上刀轴挡圈	retaining ring	2
4	10011177	螺钉	screw	2
5	10009434	上刀轴曲柄	crank of upper knife drive	1
6	10009164	螺钉	screw	1
7	10002942	上刀轴传动连杆	connecting bar of upper knife drive	1
8	10009432	直针连杆销	pin for connecting bar	1
9	10009109	螺钉	screw	1
10	10002939	螺钉	screw	2
11	10009068	上刀架	upper knife holder	1
12	10009037	螺钉	screw	1
13	*	上刀	upper knife	1
14	10009483	螺钉	screw	1
15	10009075	螺钉	screw	1
16	10058572	弹簧挡板	fender of spring	1
17	10014399	弹簧	spring	1
18	10009045	下刀架	lower knife holder	1
19	*	下刀	lower knife	1
20	10009043	下刀压板	press plate for lower knife	1
21	10055368	螺钉	screw	1
22	10009656	上刀架	upper knife holder	1
23	10008165	下刀架	lower knife holder	1
24	10009301	下刀架	lower knife holder	1
25	10023652	下刀架	lower knife holder	1
		*:参看专用件表/see the gauge list		

16. 压脚机构/ PRESSER FOOT ASSEMBLY

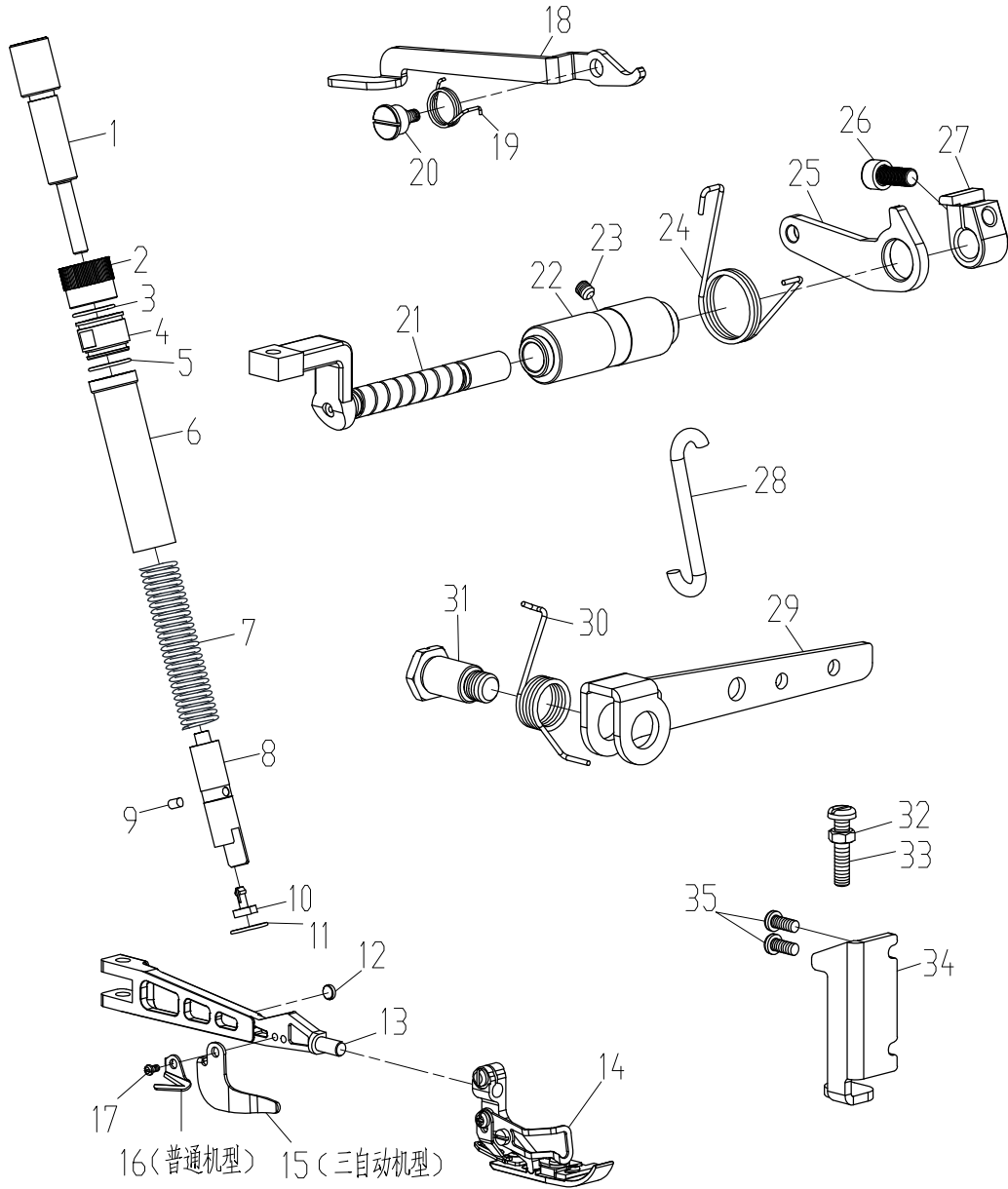



## 16. 压脚机构/PRESSER FOOT ASSEMBLY

序号 No.	件号 Parts No.	名称	Description	数量 QT.
1	10058290	调压螺钉	screw for adjusting pressure of presser foot	1
2	10057465	调压螺母	nut for adjusting pressure of presser foot	1
3	10057462	O型圈	O ring	1
4	10057460	压脚杆螺纹套	press pin threaded sleeve	1
5	10057464	O型圈	O ring	1
6	10062471	压脚杆塑料套	press pin plastic cover	1
7	10062472	弹簧	spring	1
8	10057455	压脚杆	bar of presser foot	1
9	10002844	销	pin	1
10	10009454	塑料垫	plastic mat	1
11	10057463	O型圈	O ring	1
12	10061365	压脚安全开关磁铁	foot safety switch magnet	1
13	10058563	压脚臂	arm of presser foot lifting	1
14	*	压脚组件	presser foot components	1
15	10037480	切刀防护板	guard plate of cutter	1
16	10011912	割线刀	secant knife	1
17	10009529	螺钉	screw	1
18	10062481	压脚扳手	hand lifter of presser foot	1
19	10063382	压脚扳手扭簧	spring	1
20	10057459	扳手螺钉	screw	1
21	10009032	压脚轴	shaft of presser foot	1
22	10061300	压脚轴套	bush of presser foot lifting	1
23	10023463	螺钉	screw	1
24	10037485	扭簧	spring	1
25	10033721	抬压脚连杆	connecting bar for presser foot lifting	1
26	10009616	螺钉	screw	1
27	10034616	抬压脚曲柄	crank for presser foot lifting	1
28	10009622	抬压脚拉杆	pulling lever for presser foot	1
29	10009158	抬压脚杠杆	lever for the presser foot	1
30	10009036	杠杆扭簧	torsing spring for lever	1
31	10036965	螺钉	screw	1
32	10009623	螺钉	screw	1
33	10009467	螺母	nut	1
34	10009159	制动板	brake plate	1
35	10009104	螺钉	screw	2
		*:参看专用件表/see the gauge list		

17. 挑线·过线机构/ THREAD TAKEUP AND THREADING FRAME

3,4线/3,4thread

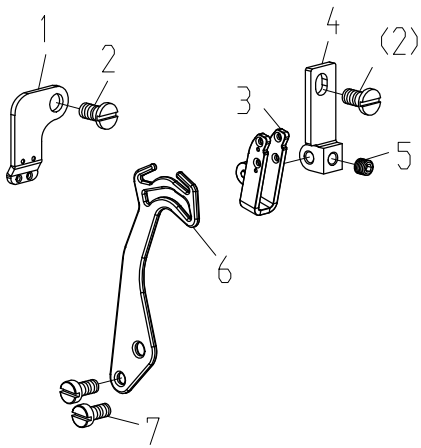

5,6线/5,6thread

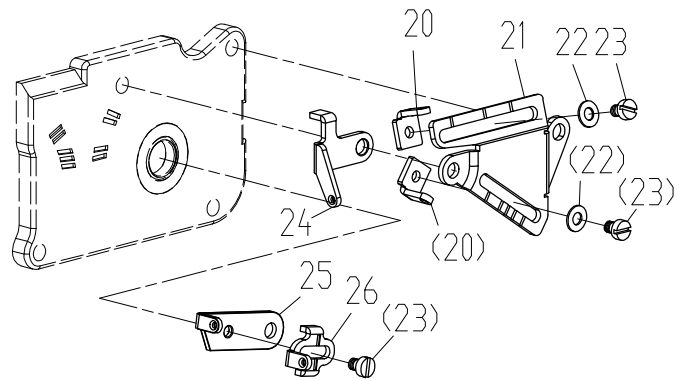
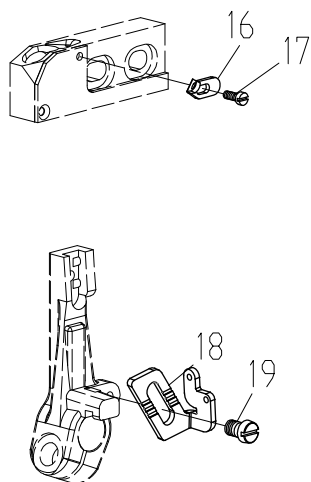
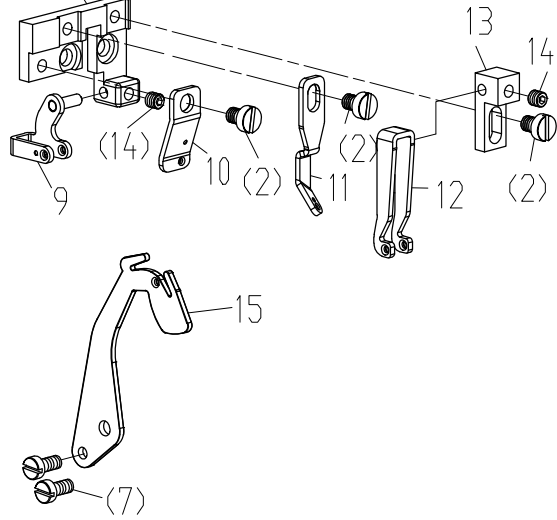

### 17. 挑线·过线机构/THREAD TAKEUP AND THREADING FRAME

序号 No.	件号 Parts No.	名称	Description	数量 QT.
1	10009014	直针过线板	thread guide plate on the needle bar	1
2	10010596	螺钉	screw	2
3	10009058	挑线夹组件	thread tension plate	1
4	10009287	挑线夹固定架	fixing stand for thread take-up clamp	1
5	10023463	螺钉	screw	1
6	10009072	挑线架	thread take-up stand	1
7	10009600	螺钉	screw	2
8	10009639	固定板	fixing plate	1
9	10009663	下挑线夹组件	lower thread tension plate	1
10	10009280	左过线板	thread guide plate of left	1
11	10003252	右过线板	thread guide plate of right	1
12	10002756	上挑线夹组件	upper thread tension plate	1
13	10057518	挑线夹固定架	fixing stand for thread take-up clamp	1
14	10009074	螺钉	screw	2
15	10009640	挑线架	thread take-up stand	1
16	10009369	上弯针小过线板	small thread guide plate of upper looper	1
17	10009353	螺钉	screw	1
18	10065093	下弯针过线板	thread guide plate for lower looper	1
19	10009363	螺钉	screw	1
20	10009013	弯针小过线板	thread guide plate of looper	2
21	10009154	弯针下过线板架	stand of lower thread guide plate	1
22	10009599	垫圈	washer	2
23	10009529	螺钉	screw	3
24	10009153	上弯针过线板	thread guide plate of upper looper	1
25	10009147	上弯针轴内过线板	inner thread guide plate mounted on the shaft	1
26	10009012	上弯针轴外过线板	outer thread guide plate mounted on the shaft	1

18. 润滑部件/ LUBRICATION ASSEMBLY

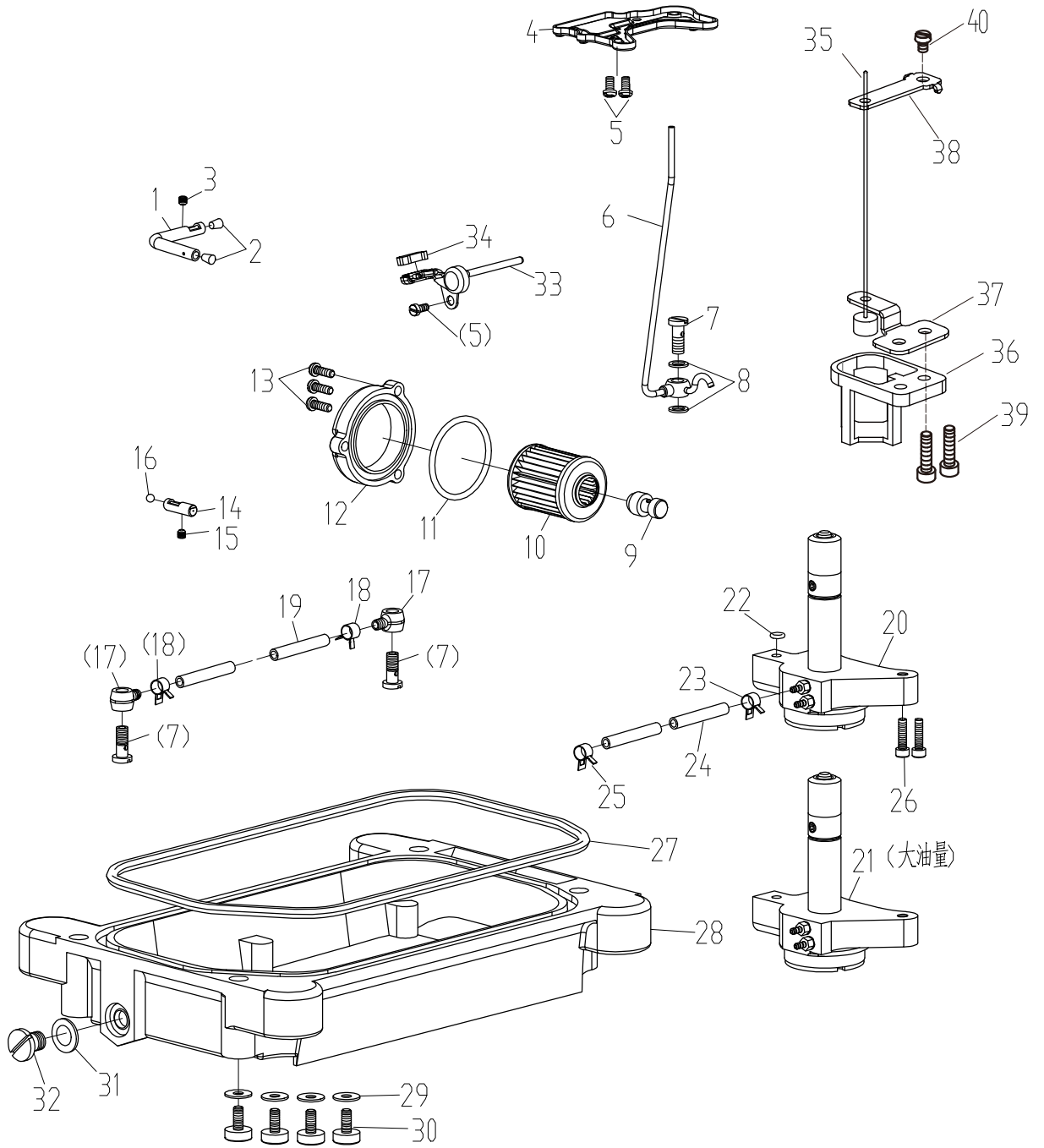

## 18. 润滑部件/LUBRICATION ASSEMBLY

序号 No.	件号 Parts No.	名称	Description	数量 QT.
1	10008992	针杆给油销	oil pin for needle bar	1
2	10009039	针杆给油销橡胶塞	rubber plug	1
3	10023463	螺钉	screw	1
4	10065655	分油板	oil distributing plate	1
5	10012710	螺钉	screw	2
6	10058565	分油管组件	Tubing assembly	1
7	10012086	垫圈	washer	2
8	10009592	螺钉接头	joint part	3
9	10026644	螺钉接头	joint part	1
10	10043169	滤油器	oil filter	1
11	10026756	O型圈	O ring	1
12	20008187	滤油器盖	oil filter cover	1
13	10009037	螺钉	screw	3
14	10012322	给油销	pin for oiling	1
15	10009074	螺钉	screw	1
16	10009826	钢球	steel ball	1
17	10009588	塑料接头	joint part	2
18	10011471	油管夹	fastening ring	2
19	10007796	油管	hose	250
20	10026648	油泵组件	assembly of oil pump	1
21	10059706	油泵蜗杆组件 (大油量)	assembly of oil pump	1
22	10003826	O型圈	O ring	1
23	10009469	油管夹	fastening ring	1
24	10007800	油管	hose	285
25	10012160	弹簧	spring	1
26	10009103	螺钉	screw	2
27	10052381	油盘垫	washer for oil tray	1
28	10052380	油盘	oil tray	1
29	10009447	垫圈	washer	4
30	10009095	螺钉	screw	4
31	10009263	垫圈组件	washer assembly	1
32	10009264	螺钉	screw	1
33	10009122	针杆回油架	oil return bush of needle bar stand	1
34	10008991	油毡	felt	1
35	10062487	油标	oil leveler	1
36	10009775	油标座	oil leveler block	1
37	10062478	油标下定位板	oil leveler lower locating plate	1
38	10062477	油标上定位板	oil leveler up locating plate	1
39	10012710	螺钉	screw	2
40	10009104	螺钉	screw	1

# 19、H·R装置/ H·R DEVICE

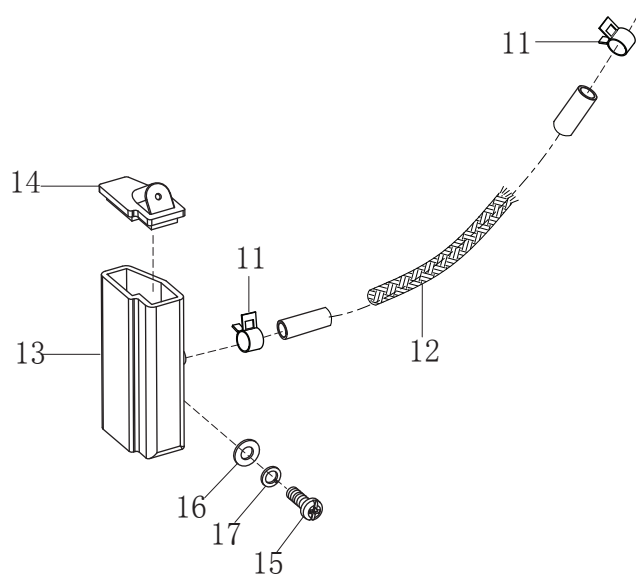
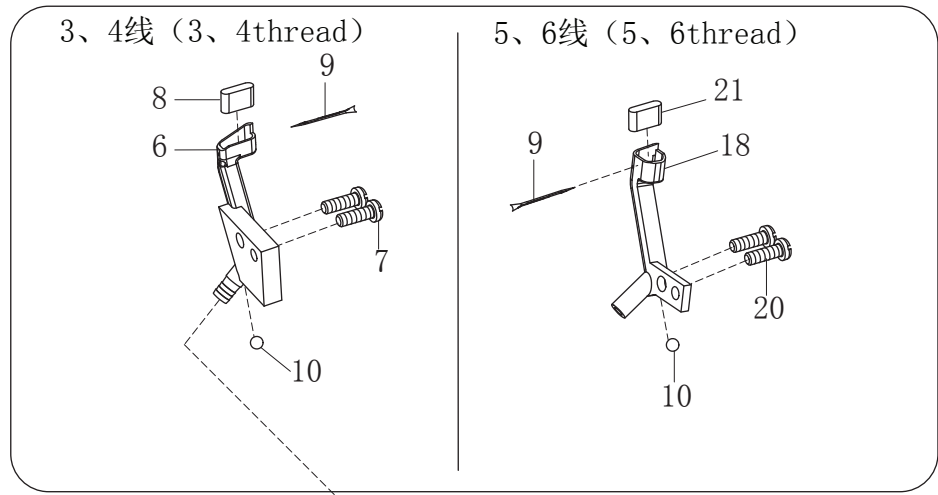
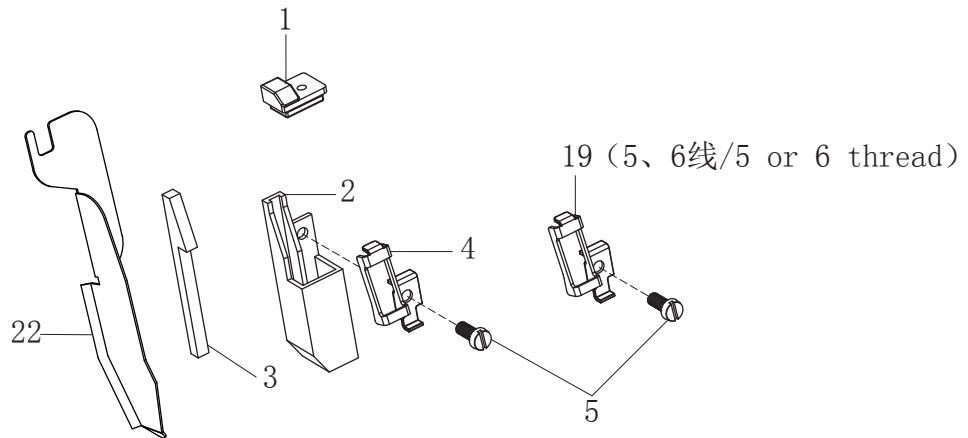



20. 电磁铁驱动抬压脚、剪线机构/ TRIM AND LIFT PRESSRE FOOT MECHANISM WITH ELECTROMAGNENT

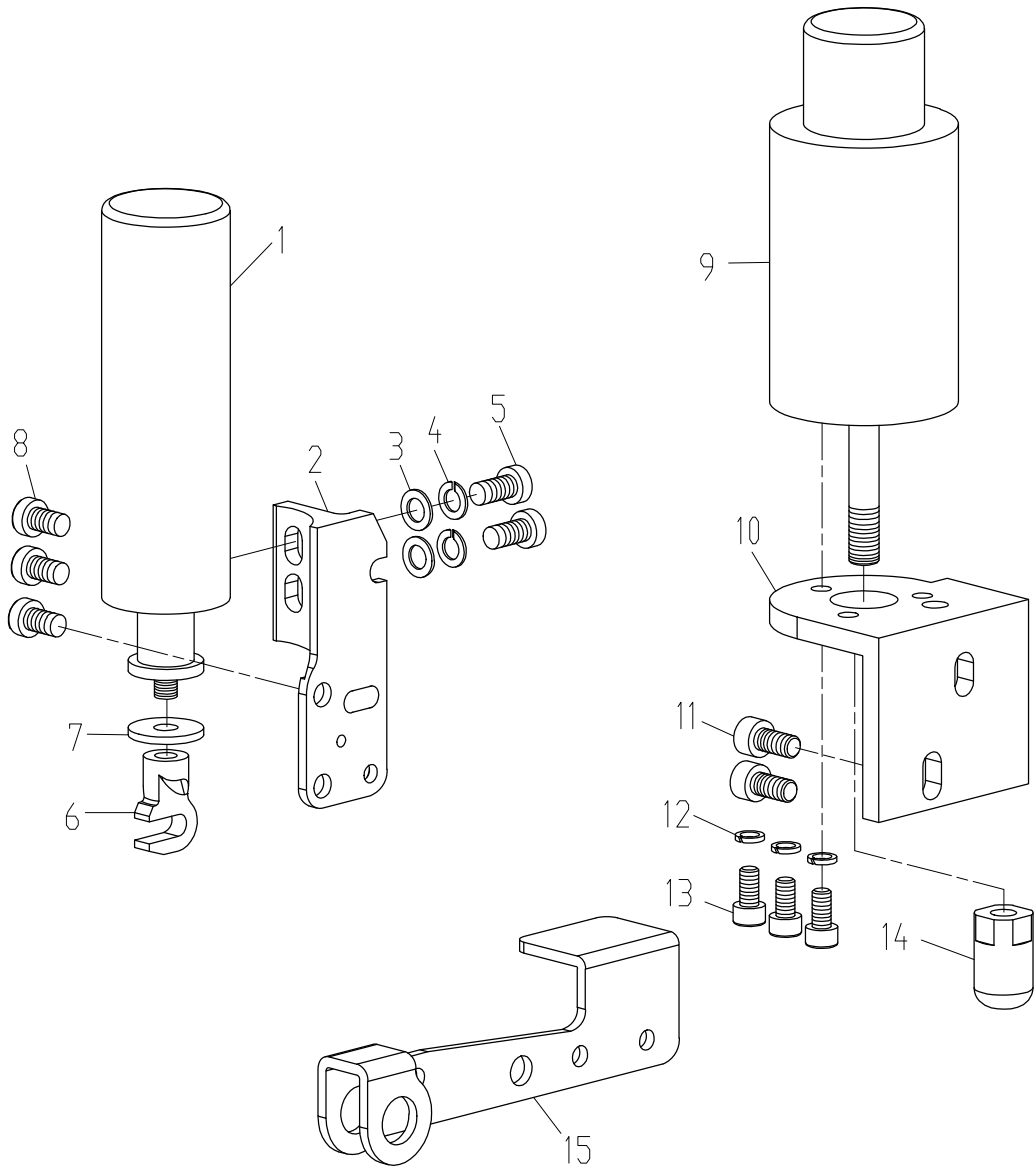



20. 电磁铁驱动抬压脚、剪线机构/TRIM AND LIFT PRESSER FOOT MECHANISM WITH ELECTROMAGNET

序号 No.	件号 Parts No.	名称	Description	数量 QT.
1	10049858	剪线电磁铁组件	electromagnet of shearing line	1
2	10053101	电磁铁安装座	the saddle of the electormagnet for shear	1
3	10010835	垫圈	washer	2
4	10052480	轻型弹簧垫圈	spring washer	2
5	10054136	螺钉	screw	2
6	10037484	剪线气缸接头	contact	1
7	10022739	垫圈	washer	1
8	10001839	螺钉	screw	3
9	10052112	抬压脚电磁铁	electormagnet of the lifting	1
10	10052113	抬压脚电磁铁固定板	plate of the fixing	1
11	10003169	螺钉	screw	2
12	10005537	垫圈	washer	3
13	10003165	螺钉	screw	3
14	10051758	抬压脚顶杆	plunger	1
15	10051759	抬压脚杠杆	lever of the lifting presser foot	1

21. 气动驱动抬压脚、剪线机构/ TRIM AND LIFT PRESSER FOOT MECHANISM WITH AIR CYLINDER

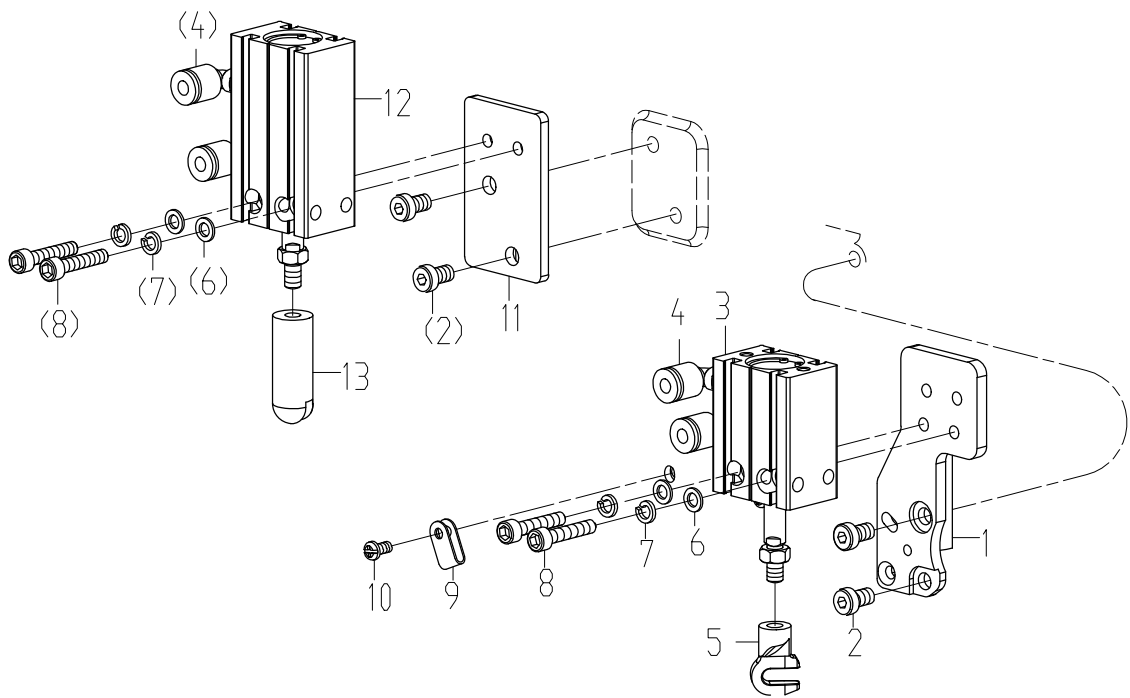

21. 气动驱动抬压脚、剪线机构/TRIM AND LIFT PRESSER FOOT MECHANISM WITH AIR CYLINDER

序号 No.	件号 Parts No.	名称	Description	数量 QT.
1	10037033	剪线气缸固定板	plate	1
2	10003165	螺钉	screw	4
3	10049556	剪线气缸	air cylinder	1
4	10037851	接头APL6-M5	joint	4
5	10037484	剪线气缸接头	joint of air cylinder	1
6	10006115	垫圈	washer	4
7	10005537	垫圈	spring washer	4
8	10006118	螺钉	screw	4
9	10053084	电线夹	line card	1
10	10014441	螺钉	screw	1
11	10001839	抬压脚气缸固定板	plate	1
12	10049555	抬压脚气缸	air cylinder	1
13	10037034	抬压脚顶杆	mandril for lefting presser foot	1



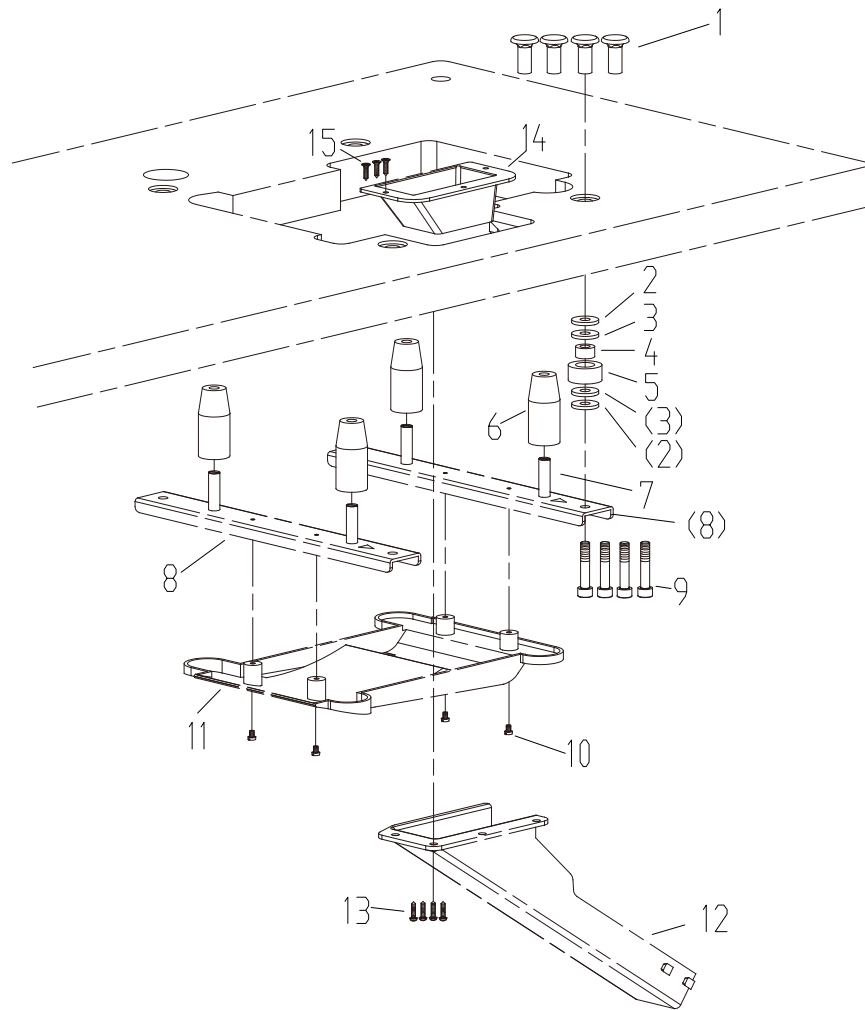





22. 油盘托架/ OIL TANK BRACKET









## 22. 油盘托架/OIL TANK BRACKET

序号 No.	件号 Parts No.	名称	Description	数量 QT.
1	10009596	螺套	bush with inner thread	4
2	10059968	塑料垫	plastic mattress	8
3	10009272	垫圈	washer	8
4	10059967	橡胶垫钢圈	rubber cushion steel ring	4
5	10059966	橡胶垫	rubber blanket	4
6	10059964	托盘橡胶垫	pallet rubber mat	4
7	10059965	支柱	brace	4
8	10059963	托盘支架	the tray support	2
9	10003106	螺钉	screw	4
10	10002924	螺钉	screw	4
11	10059962	托盘	tray	1
12	10033825	下料槽包装组件	the manger packing assembly	1
13	10004981	螺钉	screw	4
14	10033756	下料口	feed opening	1
15	10051357	螺钉	screw	3

规格件表 GAUGE PARTS LIST

							
MODEL	NEEDLE PLATE	MAIN FEED DOGASSY	DIFF. FEED DOG	PRESSER FOOT	UPPER LOOPER	LOWER LOOPER	CHAINSTITCH DOGASSY
机型	针板	主送料牙组	差动送料	压脚组件	上弯针	下弯针	链弯针
B9500-17-*	10009769	10009112	10009107	10009768	10009368	10008565	-
B9500-17H-*	10008579	10008554	10008580	10008581	10008602	10008565	-
B9500-13-*	10009380	10009112	10009107	10054662	10009368	10008565	-
B9500-13H-*	10008567	10008662	10008566	10052572	10008633	10008565	-
B9500-13NW	10053177	10053179	10053178	10053184	10009368	10008565	-
B9500-38-*	10009282	10009767	10009288	10009289	10009368	10008565	10009304
B9500-70-*	10009662	10009767	10009645	10009281	10009368	10008565	10009304
B9500-86-*	10008570	10008572	10008569	10008646	10008602	10008565	10008612
B9500-355-*	10008161	10009767	10009645	10008167	10009368	10008565	10009304

规格件表 GAUGE PARTS LIST

							
MODEL	UPPER KNIFE	LOWER KNIFE	FRONT NEEDLE	REAR NEEDLE	NEEDLE HOLDER	NEEDLE	THREAD STAND PARTS
机型	上刀	下刀	前护针	后护针	针夹	机针	线架
B9500-17-*	10009611	10010866	10009377	10009023	10003434	DC×27#11	10006347
B9500-17H-*	10008556	10008604	10009377	10009023	10003434	DC×27#18	10006347
B9500-13-*	10009611	10010866	10009377	10009023	10009340	DC×27#11	10007906
B9500-13H-*	10009611	10010866	10009377	10009023	10009340	DC×27#11	10007906
B9500-13NW	10009611	10008556	10009377	10009023	10009340	DC×27#11	10007906
B9500-38-*	10009611	10010866	10009637	10009023	10009284	DC×27#14	10004956
B9500-70-*	10009611	10010866	10009637	10009023	10003293	DC×27#14	10004956
B9500-86-*	10008556	10008604	10009637	10009023	10008549	DC×27#21	10004956
B9500-355-*	10009611	10010866	10009637	10009023	10008162	DC×27#11	10005969

注：上述规格表中的“\*”代表“ED2”、“ED3”、“PD3”“SD3”等机型（例如：B9500-13-\*，对应的机型有B9500-13-ED2、B9500-13-ED3、B9500-13-PD3、B9500-13-SD3）。